

Operating Instructions Comfort Lift Door Drive AT 25_A

Date of issue 04/04

SIEMENS

Siemens Electronic Design
and Manufacturing Services

1 Table of Contents

1	Table of Contents.....	1
2	Introduction	2
3	Notes on Safety	3
4	Overview of Controls and Indicators	4
5	Functions and Device Reactions	5
	5.1 Learning and Test Run.....	5
	5.2 DOOR-OPEN Command	5
	5.3 DOOR-CLOSE Command.....	5
	5.4 Service Buttons.....	5
	5.5 Detection of Blocking.....	6
	5.6 Restart after Voltage Loss.....	6
	5.7 Closing Force.....	6
	5.8 Emergency Release	6
	5.9 Nudging.....	7
	5.10 Light Barrier.....	7
	5.11 Emergency Electric Power Supply	7
	5.12 Overload Protection.....	7
	5.13 User Terminal	8
6	Mechanical Assembly and Setting	9
7	Electric Setting and Commissioning.....	10
8	Relay Contacts.....	13
9	Travelling Curve	14
10	Display of Operating State.....	15
11	Speed Limit	16
12	Technical Data.....	17
	12.1 D.C. Gear Motor (Overall Door Mass 120 and 400 kg).....	17
	12.2 Mains Transformer (Overall Door Mass 120 and 400 kg).....	17
	12.3 Control Device AT 25A (Overall Door Mass 120 and 400 kg).....	18
	12.4 Tests.....	18
13	Appendix.....	19
	13.1 Appendix 1: Ident. Numbers of the Individual Parts	19
	13.2 Appendix 2: Dimension Sheet Control Device AT 25A.....	20
	13.3 Appendix 3: Dimension Sheet Mains Transformer AT 25A.....	21
	13.4 Appendix 4: 40 V Gear Motor, Driving Pinion Left, with Rubber-Metal Connection and Assembly Bracket.....	22
	13.5 Appendix 5: 30 V Gear Motor, Driving Pinion Right, with Rubber-Metal Connection and Assembly Bracket.....	23
	13.6 Appendix 6: Deflection Roller with Tightening Device and Assembly Bracket	24
	13.7 Appendix 7: Door Carrier.....	25
	13.8 Appendix 8: Assembly Recommendation.....	26
	13.9 Appendix 9: Wiring Diagram Control Inputs.....	27
	13.10 Setting Log:.....	28

2 Introduction

The comfort lift door drive AT 25A is an "intelligent" door drive which is used to actuate lift car doors and landing entrances at adjustable speeds and accelerations.

The maintenance-free drive unit consists of a d.c. motor with a nonselflocking gear and is operated with speed control. The transmission is performed using a toothed belt. The toothed belt is guided across a deflection roller and can be equipped with two door carriers. Thus, doors opening on one side as well as centrally opening doors can be driven.

Two variants of motor are available:

- 40 V motor, 1.65 A for maximum 120 kg overall door mass
- 30 V motor, 4.0 A for maximum 400 kg overall door mass

Both door drives can be ordered with a differently mounted driving pinion (left or right, refer to drawing in Appendix).

The controller identifies the type of the connected motor automatically.

No limit switches are required for the operation of the door drive. The door width as well as the positions "OPEN" and "CLOSE" are automatically determined.

The current operating states are shown on a 7-segment display (IC-206) in the control device.

For all important dimensioned drawings, an assembly recommendation and the ident. numbers to order the individual drive components refer to the Appendix.



NOTE

These operating instructions do not contain detailed information on all types of the product for clarity reasons and can not take into account each possible case of the assembly, operation, or maintenance. Should you require more information, or should particular problems occur which are insufficiently described in the operating instructions, please contact our AT service hot line for the required information (Tel.: +49 511 8 77-12 71 und +49 511 8 77-12 57). Besides we point out that the content of these operating instructions is not part of an earlier or existing agreement, obligation or facts of the case or should alter these. All Siemens liabilities ensue from the respective bill of sale that also contains the complete and solely valid warranty regulations. These contractual warranty regulations are neither extended nor limited by the performance of these operating instructions.



3 Notes on Safety

Prior to commissioning, observe the following

Thoroughly read the operating instructions at hand through. They contain important information on installation, use, and safety of the device.

Specific Notes

Three types of specific notes are used in the operating instructions to stress important information:

	<p>WARNING in these operating instructions means that death, heavy bodily injuries or serious damage to property may occur, if the respective precautions are not taken!</p>
	<p>CAUTION in these operating instructions means that minor bodily injuries or damage to property may occur, if the respective precautions are not taken.</p>
	<p>NOTE in these operating instructions provides important information about the product or the respective part of the operating instructions which should be paid attention to in particular.</p>



WARNING

Only qualified staff should work on this device or in its vicinity. The staff must thoroughly be informed about all warnings and maintenance measures according to these operating instructions.

To ensure the correct and safe operation of this device, proper transport storage, erection, and assembly as well as careful operation and maintenance are required.

The entire electric wiring has to be checked for correct and safe connection. All connectors have to be secured by screws.

Qualified staff in these operating instructions and/or warnings are persons who are familiar with erection, assembly, commissioning, and operation of the product and possess respective qualifications required for the job as e.g.:

- training or instruction and/or right to switch on/off electric circuits, and devices/systems according to the standards of the safety engineering
- training or instruction in attendance and use of appropriate safety equipment, according to the standards of the safety engineering
- training in first aid

4

Overview of the Controls and Indicators

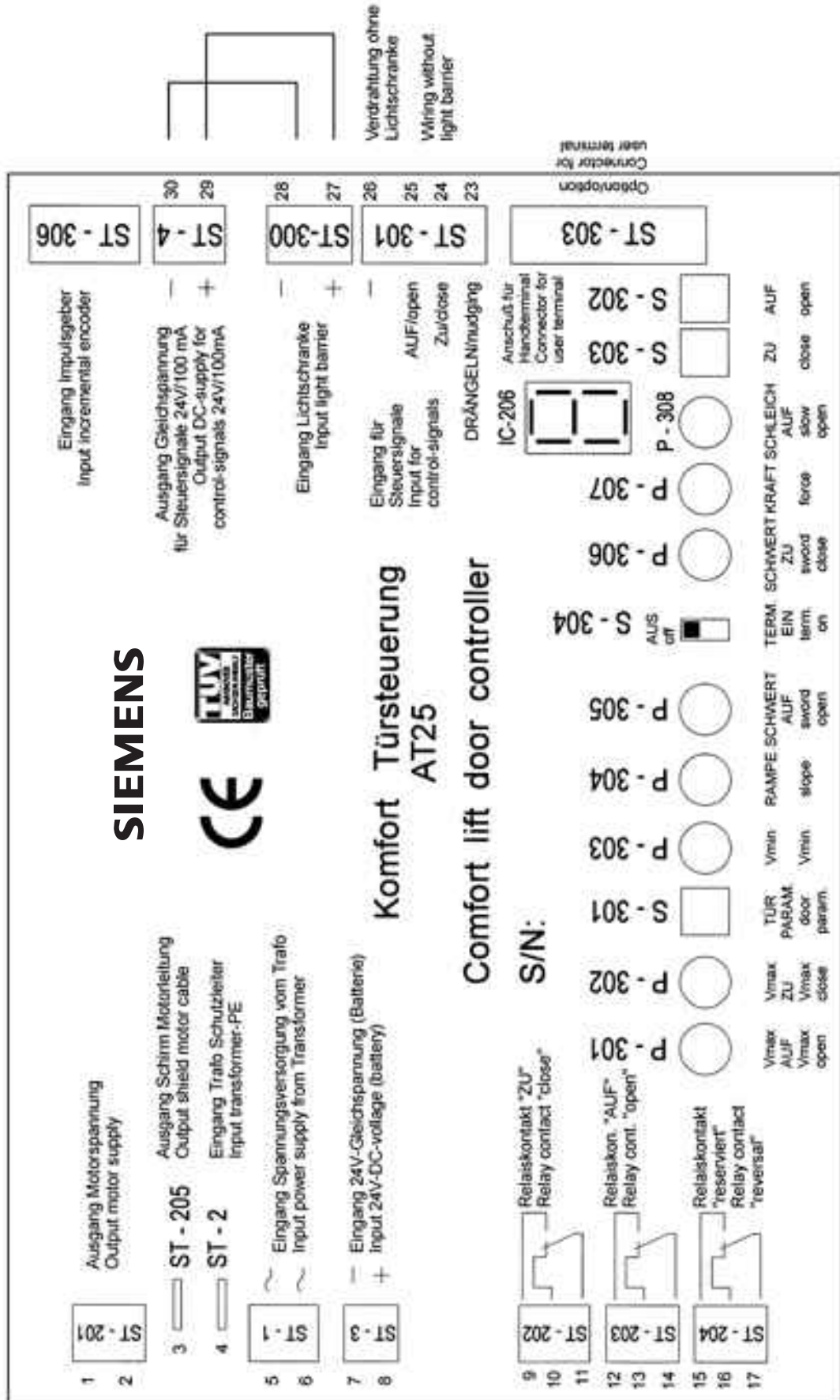

5 Functions and Device Reactions

5.1 Learning and Test Run

By actuating the *button DOOR-PARAM.* (S-301) the automatic parameter determination is performed:

1. Detection of the motor type
2. Detection of the door movement direction and the position "OPEN"
3. Determination of the door width and the position "CLOSE"
The storing of the parameters is performed in position "CLOSE" and takes approx. 5 s.

5.2 DOOR-OPEN Command

When the *DOOR-OPEN command* is provided the door opens according to the set travelling curve as long as the command is set. The transition points of the travelling curve (e. g. from acceleration to steady condition) are rounded to avoid noises which may be produced through the play between the lift car door and the landing entrance. The door reaches the *position "OPEN"* at slow speed. Subsequently, the door is held open with a reduced moment.

- The *DOOR-OPEN command* must be set during the entire opening procedure.
- The *DOOR-OPEN command* has priority over all other control commands.



NOTE

The first opening procedure is performed at slow speed after the commissioning.

5.3 DOOR-CLOSE Command

To close the door, the *DOOR-CLOSE command* must be set permanently. After closing, the door is held closed with a reduced moment as long as the *DOOR-CLOSE command* is set.

5.4 Service Buttons

Using the *service buttons OPEN* (S-302) and *CLOSE* (S-303) the door can be opened and closed from the control device.

5.5 Detection of Blocking

If the door is blocked due to an obstacle when closing, it stops and reverses. The door repeats this action maximum 5 times at the speeds of the set travelling curve. Subsequently, it switches over to slow run and tries on finishing the closing procedure. After removal of the obstacle and completion of the closing procedure the usual door performance is reached again.

If the door is blocked when opening, it is reactivated at slow speed with 2 s waiting time. The door repeats this action maximum 3 times. Should the door still be blocked after the third attempt, it closes at slow speed and also opens at slow speed when the next *DOOR-OPEN command* is set.

5.6 Restart after Voltage Loss

After voltage loss the door must perform a test run in *direction CLOSE*. It is carried out when the next *DOOR-CLOSE command* is set. This test run can not be performed if the light barrier is covered (from software version 1.35 on).

5.7 CLOSING FORCE

The closing force can be set between 70 and 230 N with 30 V motor and between 70 and 160 N with 40 V motor. If 150 N are exceeded the flashing *7-segment display (IC-206)* issues a warning.

**CAUTION**

When setting the closing force an active closing weight must absolutely be taken into account.

Example: Closing weight = 4 kg

Turn *potentiometer P-307* counterclockwise until *7-segment display (IC-206)* shows "4" without flashing. The resulting closing force is then 150 N.

5.8 Emergency Release**WARNING**

An emergency release can only be performed, if:

- neither a *DOOR-OPEN* nor *DOOR-CLOSE command* is set,
- the *service buttons* are not actuated,
- the door is at a standstill.

Only in these cases the door drive is moment-free.

The force necessary for opening the door is below 300 N according to TRA- and EN81 requirement.

5.9**Nudging**

The door does not reverse in the operating state *NUDGE*. The *DOORCLOSE* and *NUDGE commands* must be set simultaneously. When an obstacle is detected the moment is revoked to the limit moment of the respective motor after 1 s.

**NOTE**

This function corresponds to the requirement for fire brigade lifts according to TRA.

5.10**Light Barrier**

The input for the light barrier signal has the same function like the *DOOR OPEN command*. Exception: If the door is open less than 1 cm, the light barrier signal is ignored.

If there is no voltage at the light barrier input, this is interpreted as if the light barrier is covered. The door can not be closed.

If the light barrier is covered the door opens. If a *DOOR-CLOSE command* is simultaneously set, the door moves in direction "*OPEN*" as long as the beam is covered.

**NOTE**

The factory preset for the breaking slope at the interruption of the light barrier is 80%.

5.11**Emergency Electric Power Supply**

In case of mains voltage failure a battery or accumulator (e. 9. lead-gel accumulator) can be connected externally, thus enabling the emergency service.

The door can be opened and closed in this state, the light barrier input is evaluated, the speed is however limited to slow speed. If the mains voltage is available again, the controller automatically switches over to normal operation.

**CAUTION**

The supply line to the external voltage source must be protected with 3.15 A slo-blo fuse by customer.

**NOTE**

The voltage must be fed continuously. The charging of the accumulator must be performed using an external charging set.

5.12**Overload Protection**

If the drive motor is heavily used due to frequent *DOOR-OPEN* and *DOOR-CLOSE commands* in short succession, the time of keeping open is automatically lengthened: the next closing procedure is delayed despite the possibly set *DOOR-CLOSE command*, the 7-segment display (IC-206) shows „4“. This prevents the motor from thermal overloading.

5.13**User Terminal**

Additional setting and diagnosis possibilities are offered by the handheld terminal. It is connected to *ST-303*. The *switch S-304* must be set to "*TERM ON*".

The handheld terminal is available as an additional option.

**NOTICE**

The handheld terminal settings are overwritten if after a performed setting a parameter determination is carried out again (later) with S-301 when switching on power supply (also refer to chapter 7 Electric Setting and Commissioning, page 10). In this case the settings are set to the delivering state. The same is true when S-304 is set to "TERM OFF" and the CLOSE position was reached. The potentiometer settings are then taken over. These values remain stored (independent of the S-304 switch setting) until they are overwritten by the handheld terminal again.

6.**Mechanical Assembly and Setting****CAUTION**

Safe operation of the lift door drive requires that it is correctly mounted and put into service by qualified staff who observe the warnings of these operating instructions.

Prior to all kinds of work at the door drive, make sure that the control system is free of voltage. Only then the standstill of the door is ensured.

The mechanical assembly and setting of the lift door drive is performed in five steps:

1. Mount the motor onto the motor support (rubber-metal connection). Subsequently, mount the motor onto the assembly bracket, if necessary.
2. Mount the deflection roller, if necessary, with assembly bracket. Make sure that the driving pinion and deflection roller are aligned: they should precisely face each other (be aligned).
3. Bolt the toothed belt together with the door carrier and put it on.

**CAUTION**

As a door carrier (toothed belt joint) only use door carriers described in the Appendix! The inappropriate fastening may cause stress concentration on the toothed belt that may result in destruction of the toothed belt!

The door carrier (toothed belt joint) must not run over the driving pinion or the deflection roller!

4. Tighten the toothed belt using the tightening device until it can be pushed in approx. 3 cm in the center.
5. Mount the control device in the vicinity of the drive motor (take into account the cable length).

7



Electric Setting and Commissioning

WARNING

During operation of electrical devices definite parts of them are inevitably under dangerous voltage.

If the operating instructions are not observed, heavy bodily injuries or damage to property may occur.

Especially all warnings must strictly be observed.

1. Open housing cover.
2. Plug *motorplug ST-201* and *ST-205*.
3. Plug incremental encoder plug on *ST-306* and fasten it with screws.
4. Set switch *S-304* to "*TERM. OFF*" position (Preset position without handheld terminal).
5. Turn all potentiometers into center position.
6. Plug light barrier plug on *ST-300*. If the light barrier input is not used, *ST-300* must be wired with *ST-4* according to the lines in the general plan.
7. Push door into position "*OPEN*".
8. Connect mains transformer with *ST-1* and *ST-2*.
9. Connect mains transformer with mains (230 V AC).
10. Immediately after connecting the mains transformer press "*DOOR PARAM*" button (*S-301*) until the *7-segment display (IC 206)* shows "*H*". It takes approx. 10 to 15 s.
11. Now the door performs a learning run. It comprises one or two opening and closing procedures in slow run over a distance of approx. 10 cm. Then the door closes at slow speed and stops in position "*CLOSE*". The *7-segment display (IC 206)* shows "*u*".
12. The button *S-302* is used now to open the door, *S-303* to close the door. The first opening is always performed at slow speed; the opening is completely carried out, even if the button was briefly flicked. For all next runs into positions "*OPEN*" and "*CLOSE*" which are controlled with the service buttons *S-302* and *S-303*, the respective button must be held on, otherwise the run is stopped. These buttons are parallel to the *OPEN* and *CLOSE* signals which are fed to *ST 301*.

13. For special applications the run values can be adapted to the door individually. The following functions are available for this purpose:

Function	Code designation	Setting Range	Potentiometer presetting (center position) at works
Maximum opening speed	V _{max} open P 301	0.1...0.8 m/s	50 %, 0.45 m/s
Maximum closing speed	V _{max} close P 302	0.1...0.8 m/s	50 %, 0.45 m/s
Minimum speed/ slow speed	V _{min} P 303	0.03...0.09 m/s	50 %, 0.065 m/s
Acceleration and braking slope	SLOPE P 304	0.3...1.4 m/s ²	50 %, 0.85 m/s ²
Sword run in OPEN direction	SWORD OPEN P 305	0...0.1 m	50 %, 0.05 m
Sword run in CLOSE direction	SWORD CLOSE P 306	0...0.1 m	50 %, 0.05 m
Maximum closing force static	FORCE P 307	70...230 N*	50 %, 150 N
Slow run in OPEN direction	SLOW OPEN P 308	0...0.1 m	50 %, 0.05 m

*Only the 30 V motor reaches the value of 230 N,
The 40 V motor does not exceed 160 N (automatically limited by software).



NOTE

Clockwise turning changes the setting in the direction of higher values.

14. The maximum static closing force can be changed by turning the potentiometer P-307. The static closing force is 150 N in center position (IC-206 displays "0"), if no counterweight is active.

**CAUTION**

The maximum static closing force must **not** exceed 150 N in view of the counterweights!

**NOTE**

All potentiometer settings or changes are taken over in *position "CLOSE"* only. The *switch S-304* must be in *"TERM. OFF"* position.

In case the door can not be held in *position "OPEN"* prior to the parameter determination because of counterweights or springs, the parameter determination must be performed from the *position "CLOSE"*:

- a) Briefly actuate the button *"DOOR PARAM."* (S-301), the door performs a learning run and stops in *position "OPEN"*.
- b) Briefly actuate the *button "DOOR PARAM."* (S-301) again, the door performs the second learning run and then stops in *position "CLOSE"*. Then the drive is ready for operation.

15. Plug the *plug ST-301* (signals for the commands *"NUDGE, OPEN* and *CLOSE"*) . Provided that the internal 24 V supply of *ST-4*, PIN 29 is used for all control signals, *PIN 26 ST-301* must be connected *with PIN 30 ST-4*.

**NOTE**

The determined, optimum settings of the parameters can be logged in the *setting log* (see Appendix Setting Log). Also this log should be kept ready for the hot line questions.

8 Relay Contacts

The relay contacts can be used to signal the following door states to the lift controller:

– *ST-202*

Door has reached the *position "CLOSE"*. The relay is switched on when the controller has detected the *position "CLOSE"* and the incremental encoder generates pulses no longer, i. e. the door stops.

PIN 11 is connected with *PIN 9* until the *Door-OPEN command* will be set. The relay is immediately released and *PIN 11* is connected with *PIN 10* again.

– *ST-203*

Door has reached the *position "OPEN"*.

The relay is switched on when the current distance between the door and the *position "OPEN"* is less than 2 cm.

Pin 12 and *Pin 14* are then connected.

If 2 cm distance is exceeded again, the relay is immediately released and *Pin 14* is connected with *Pin 13* again.

– *ST-204*

The door reverses.

The relay is switched on when the door reverses e. g. due to blocking.

The relay is also switched on if a *DOOR-OPEN command* is set, or the light barrier is covered during the closing procedure.

Pin 15 is then connected with *Pin 17*.

In the *"Overview of Controls and Indicators"* the contacts are shown in idle state.

9 Travelling Curve

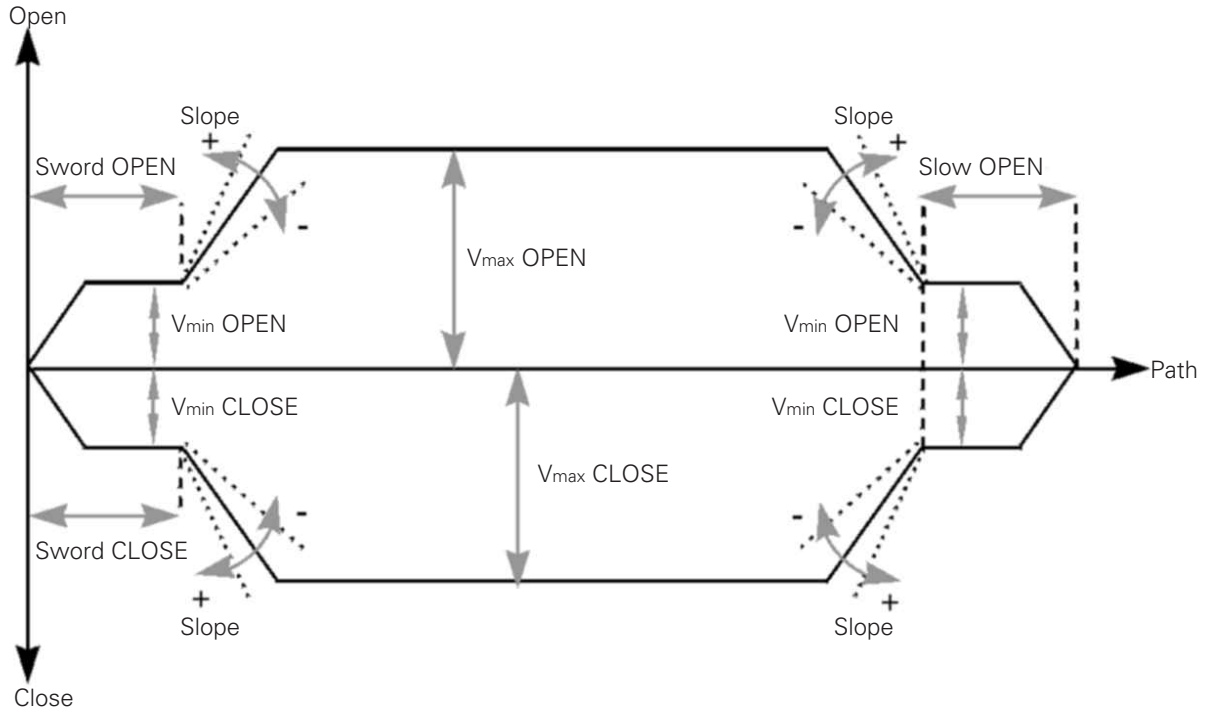

NOTE

The values for "Vmin OPEN" and "Vmin CLOSE" can only be adjusted separately by using the handheld terminal.

10 Display of Operating State

The 7-segment display IC-206 shows following operating states:

Display	Meaning
0	Light barrier signal is set
1	RAM, EPROM or CPU error
2	EEPROM error
3	error in AD converter
4	Extra time for keeping open when motor operating time is increased
5	error ASIC serial
6	Motor is blocked
7	Error incremental encoder
8	Starting test (approx. 10 s) is not finished yet or control system is defective
9	Motor overcurrent
R	Door is stopped during the first run by OPEN signal or light barrier
Ɔ	Threefold blocking when opening
E	Motor overvoltage
F	Motor undervoltage
H	Parameter determination
L	Error of current measurement
o	Function O. K.
P	Parameter error
u	Door is closed

11 Speed Limit Curve

The speed limit curve is a characteristic line for determination of the max. permissible door speed V_{\max} depending on the overall door mass.

According to EN 81 the maximum kinetic energy of the door in a closing direction must not exceed 10 Joule. $W_{\text{KIN}} = 1/2 m v^2 \leq 10 \text{ J}$.

Example from the following speed limit curve:

Overall door mass $m = 250 \text{ kg} \Rightarrow V_{\max} = 0,28 \text{ m/s}$.

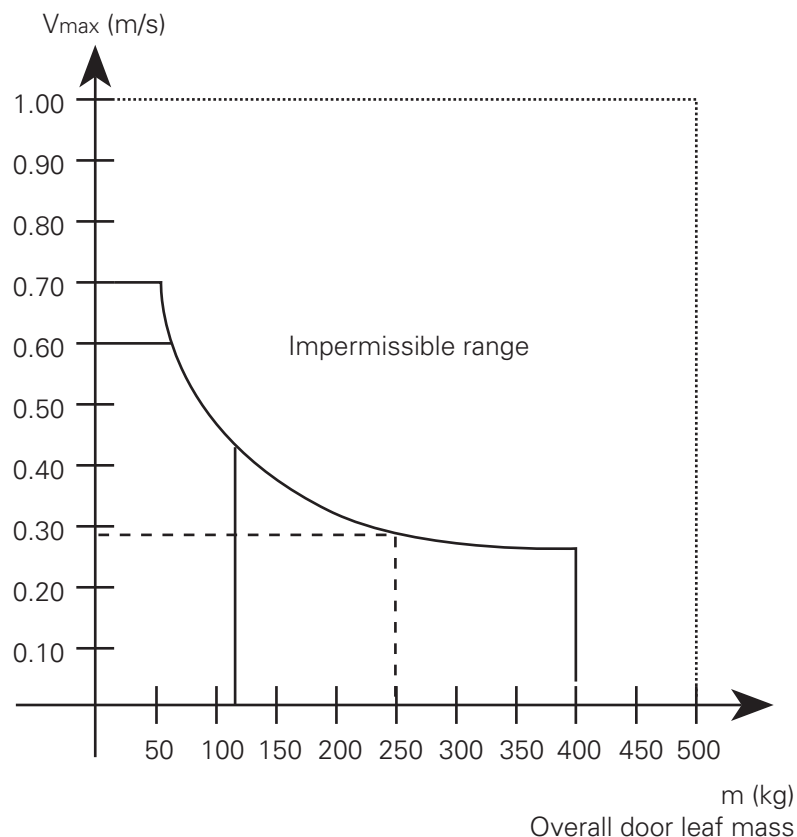

NOTE

The speed can be set between 0 (corresponds to 0.10 m/s) and 100 % (corresponds to 0.80 m/s).

40 V motor reaches maximum 71 % (corresponds 0.60 m/s),
30 V motor reaches maximum 85 % (corresponds 0.70 m/s).

12 Technical Data

12.1 D.C. Gear Motor (Overall Door Mass 120 and 400 kg)

	120 kg	400 kg
Rated voltage	max. 40 V DC	max. 30 V DC
max. speed	0,6 m/s	0,7 m/s
System of Protection	IP 20	IP 20 (optional IP 54)
Transmission	15:1	15:1
Incremental encoder	RE 30	RE 30
Rated current	1.65 A	4.0 A

12.2 Mains Transformer (Overall Door Mass 120 und 400 kg)

Mains voltage	230 V, 50-60 Hz	
Tolerance	±15 %	
Max. current consumption	2.2 A	
System of Protection	IP 54	
Rated output-voltage	22 V	
max. current secondary	15.9 A	
Fuse	5 x 20 T16 A secondary	
Mains filter	built-in	

12.3 Steuergerät AT 25A (Gesamttürblattmasse 120 und 400 kg)

Mains voltage	22 V AC
Fuse	5 x 20 T2,0 A
System of protection	IP 20
Control inputs	+10 V to +28 V DC, 9 to 27 mA (potential-free, p-switching)
Door width	0.25 m to 4.00 m
Switching capacity output relay	230 V AC, 1,0 A (min. 10 mA)
max. perm. storing temperature	- 40 ... +85 °C
max. perm. operating temperature	- 20 ... +50 °C no direct insolation!
Humidity stress	no thawing
Emergency power input	24 V ± 15%, 1.6 A (e. g. lead-gel accumulator)
recommended accumulator capacity	2 Ah, protection by customer (!) with T 3.15 A. An opening and closing cycle requires an amount of energy up to 2.4 Wh (0,1Ah at 24V).
24 V output	max. output current 100 mA, short circuit-proof and overload-proof CAUTION: Do not feed external voltage!

12.4 Tests

EMV test	EN 55022 and EN 50082_2
TÜV (MOT)	type tested
CE	certified

13 Appendix

13.1 Appendix 1: Ident. Numbers of the Individual Parts

Ident. Nr.	Plain Text	Code Designation
Control Device		
10005711	AT 25A, incl. mains transformer	AT 25A
Gear Motor		
10005250	40 V motor, pinion left, doors up to 120 kg	AT1-40-120-L
10004691	40 V motor, pinion right, doors up to 120 kg	AT1-40-120-R
10005678	30 V motor, pinion left, doors up to 400 kg	AT2-30-300-L
	30 V motor, pinion right, doors up to 400 kg	AT2-30-300-R
Accessories		
070220808	Rubber-metal connection support 40 V motor	AT 1 rubber-metal connection
070220794	Rubber-metal connection support 30 V motor	AT 2 rubber-metal connection
070220816	Assembly bracket for gear motor (both motors)	Assembly bracket for motor
070220824	Assembly bracket with tightening device for deflection roller	Assembly bracket for deflection roller
070040052	Door carrier, 2 pieces	
070040060	Deflecting device (both motors)	
070220352	Incremental encoder cable (both motors)	
070040028	Toothed belt 4 m (both motors)	
070040087	Toothed belt 45 m (both motors)	

13.2 Appendix 2:
Dimension Sheet Control Device AT 25A

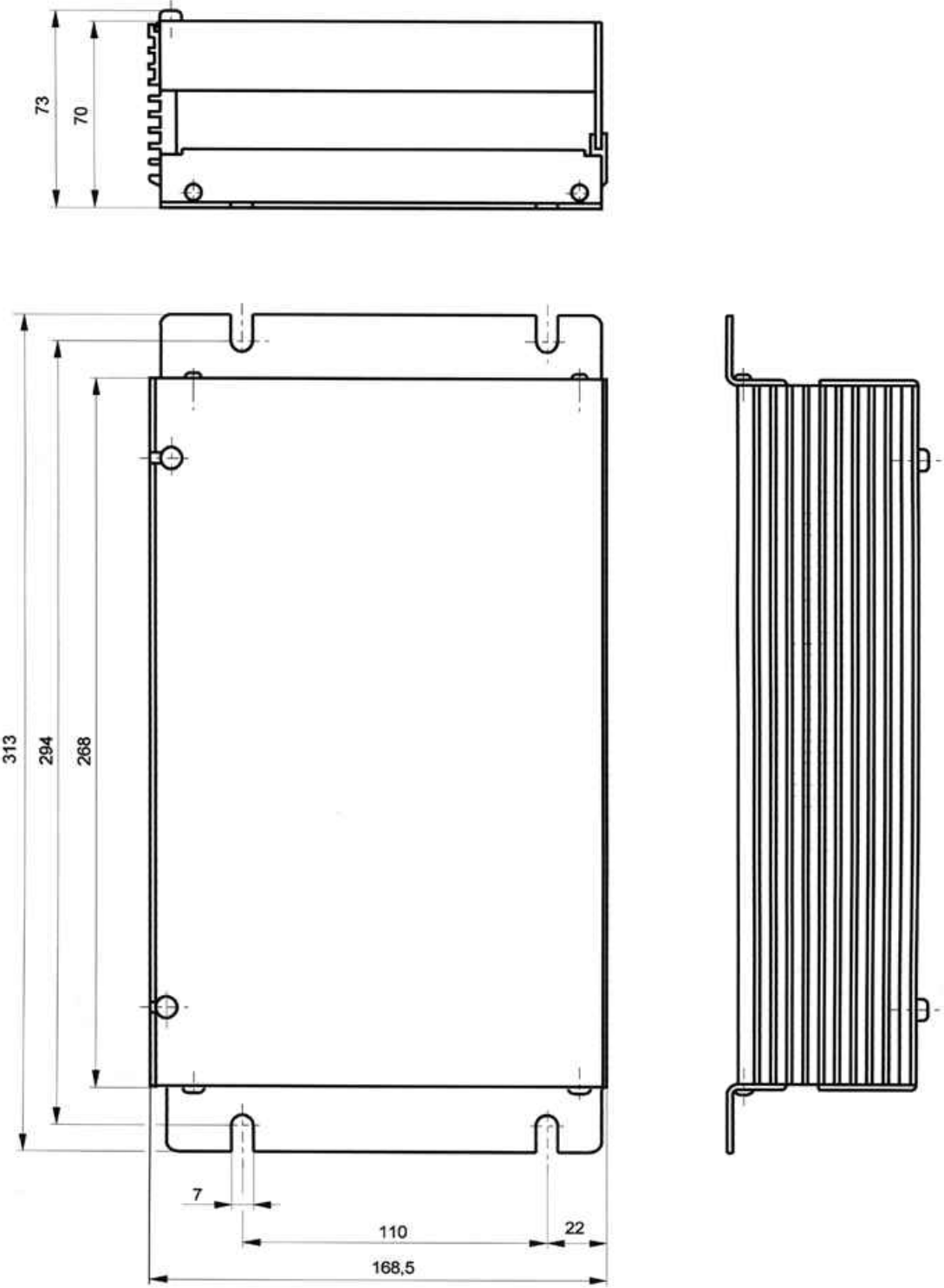

13.3

Appendix 3:

Dimension Sheet Mains Transformer AT 25A

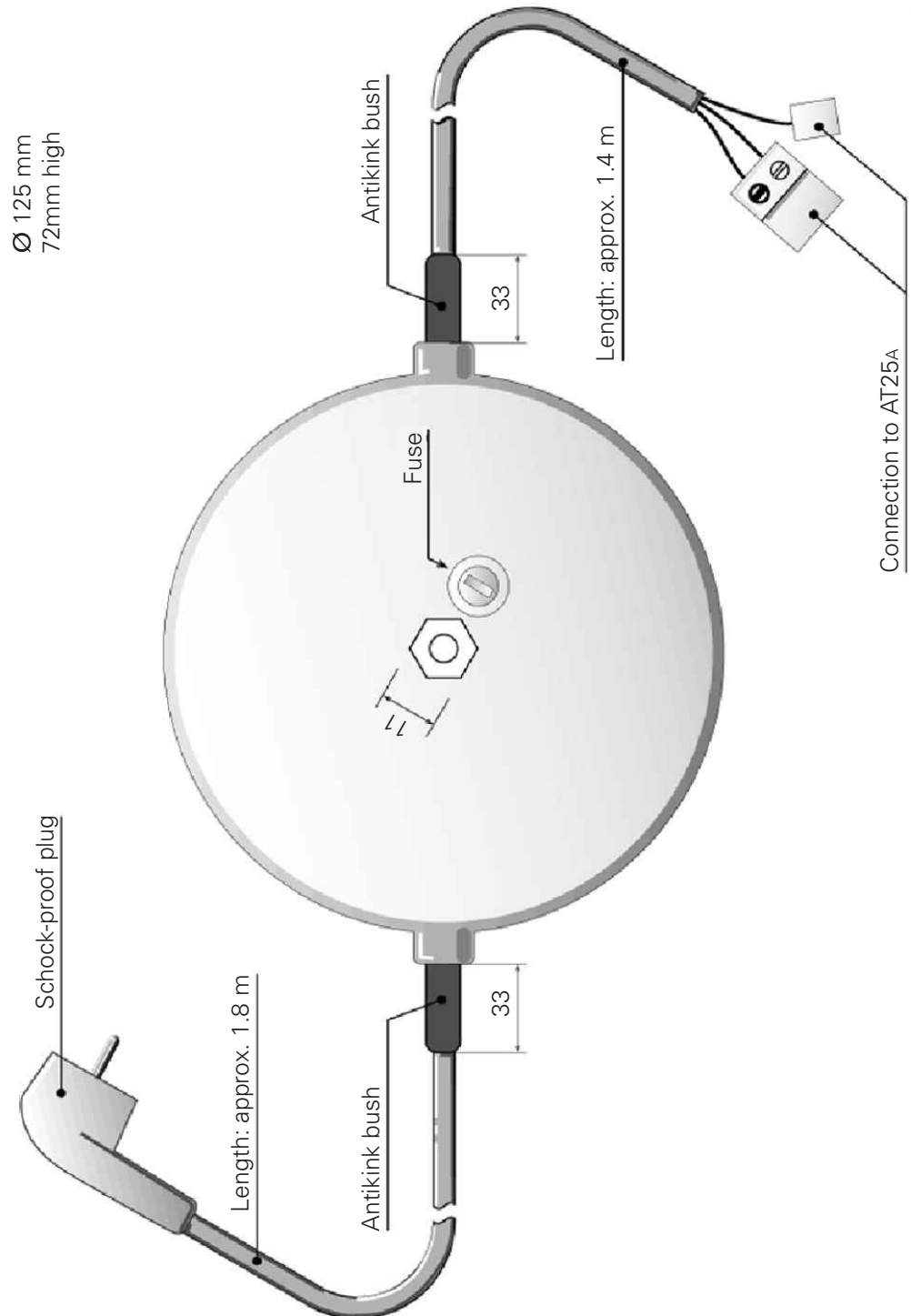

13.4

Appendix 4:

**40 V Gear Motor, Driving Pinion Left,
with Rubber-Metal Connection and Assembly Bracket**

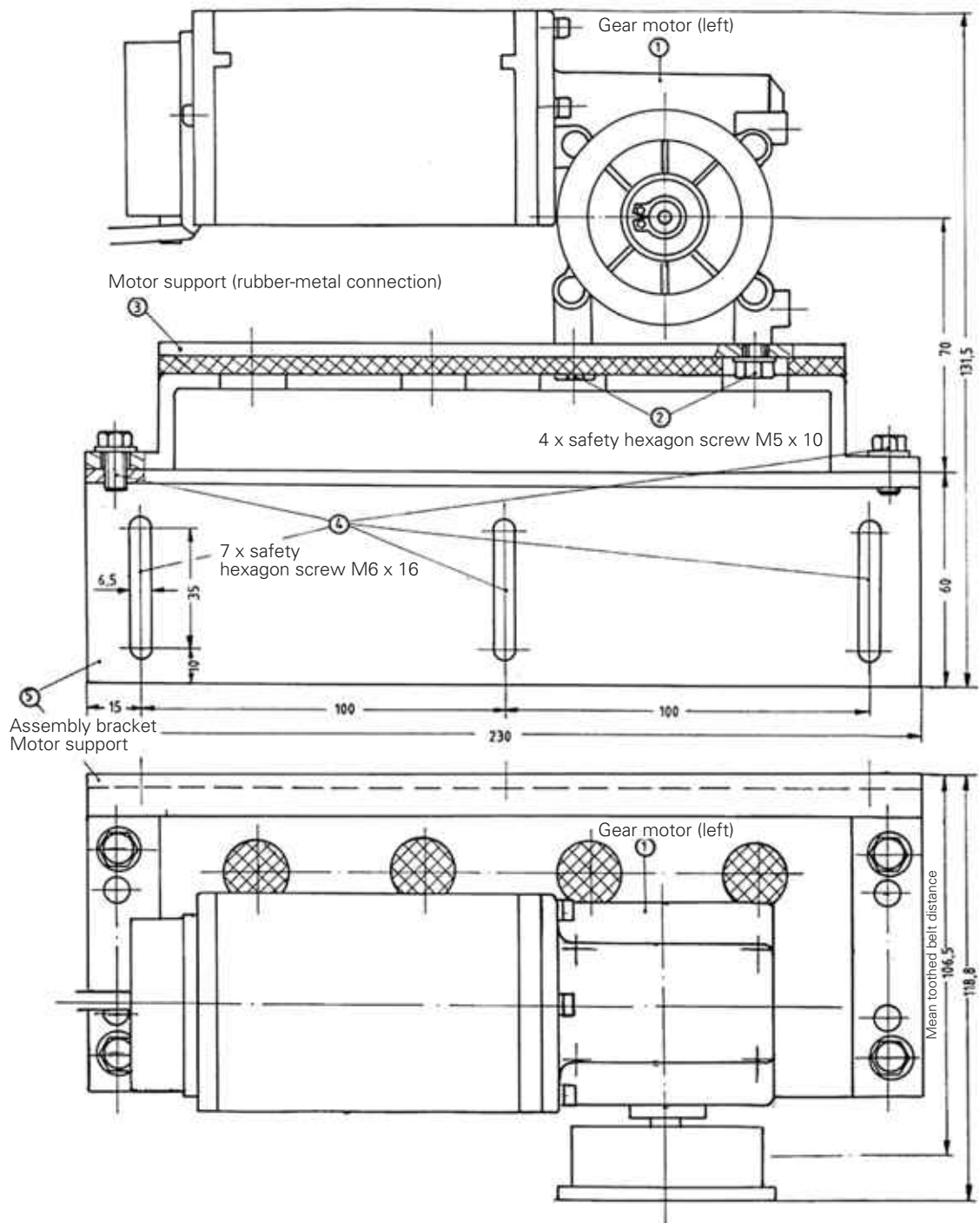

13.5 Appendix 5: 30 V Gear Motor, Driving Pinion Right, with Rubber-Metal Connection and Assembly Bracket

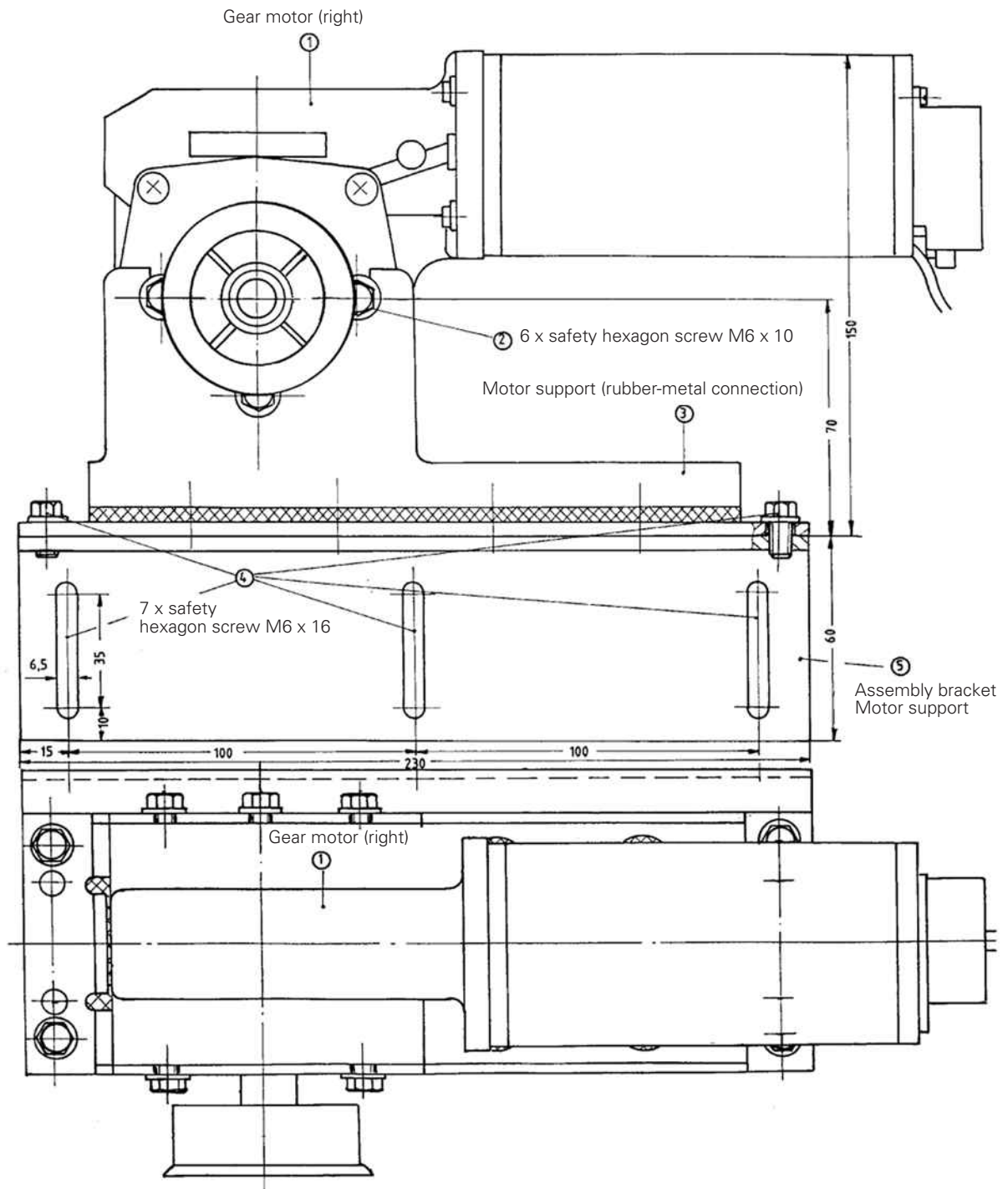

13.6

Appendix 6:

Deflection Roller with Tightening Device and Assembly Bracket

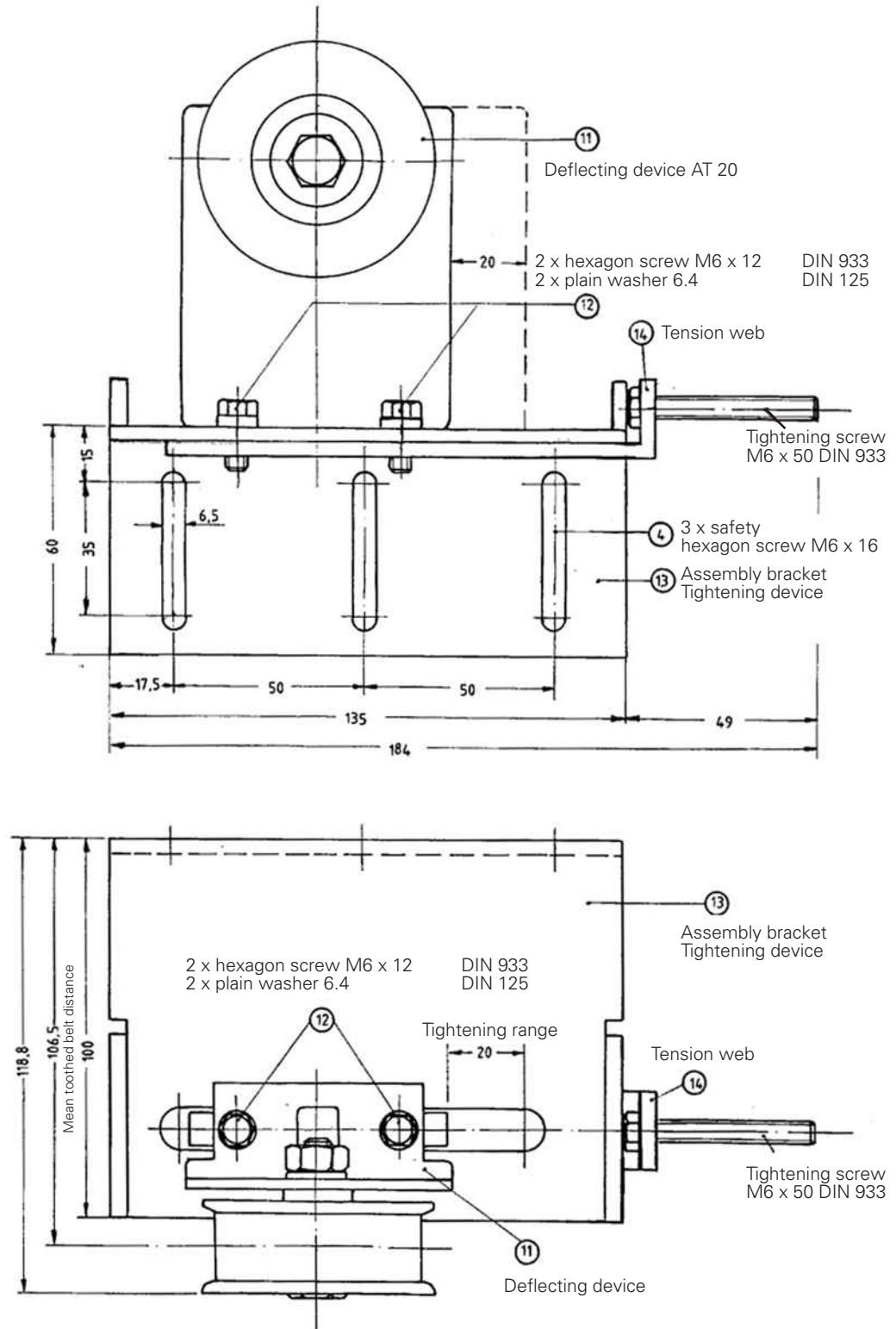

13.7 Appendix 7: Door Carrier

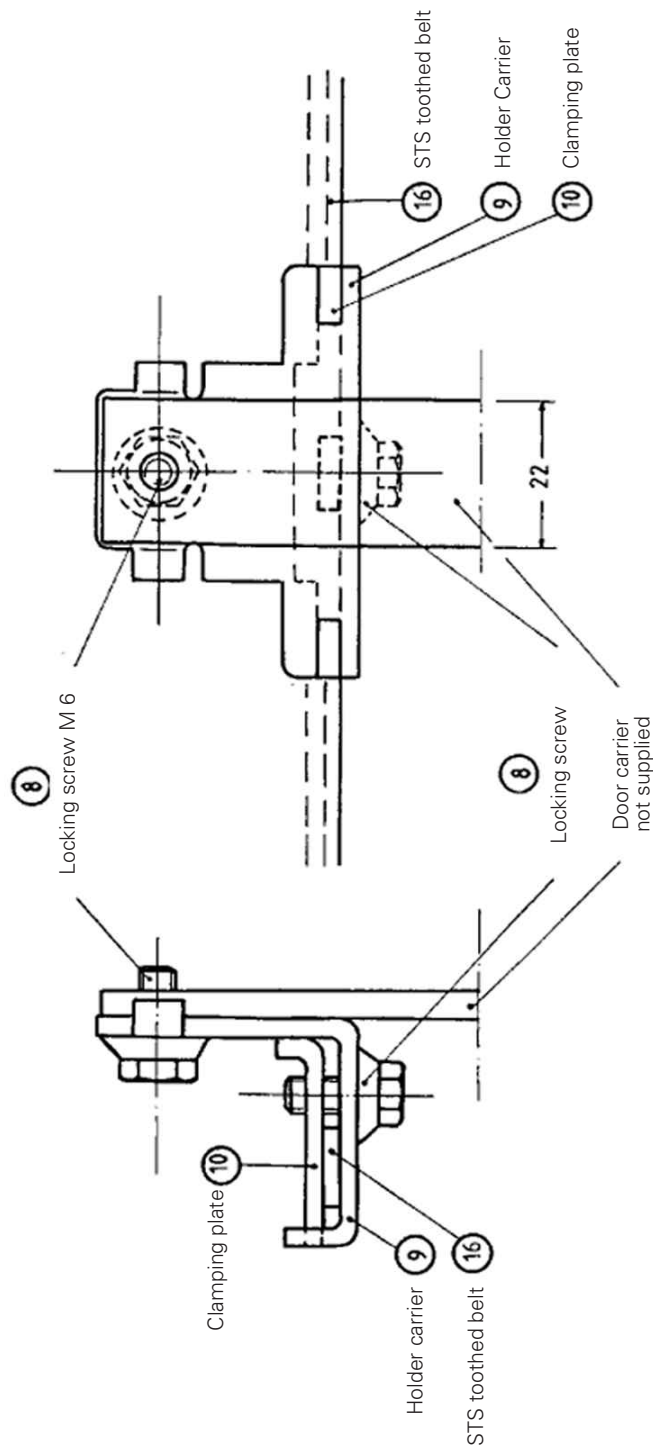

13.8

**Appendix 8:
Assembly Recommendation**

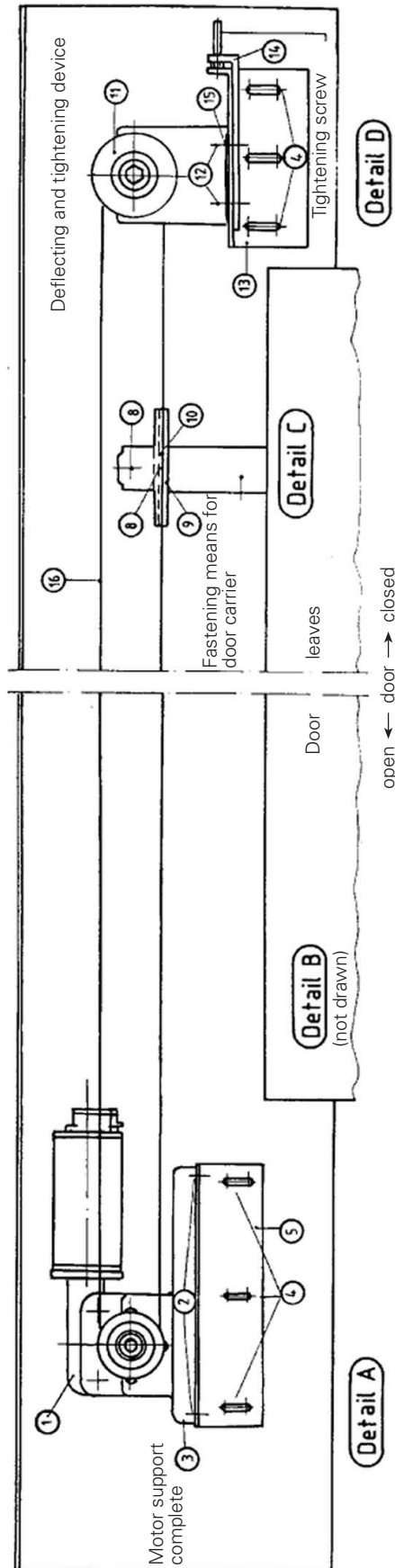

⌀ standard length

1. Gear motor
2. 4 x hexagon screw with plain washers
3. Motor support
4. 6 x hexagon screw M6 x 16 with plain washers
5. Assembly bracket motor support
8. 2 x safety hexagon screw M6 x 12 door carrier

13.9 Appendix 9: Wiring Diagram Control Inputs

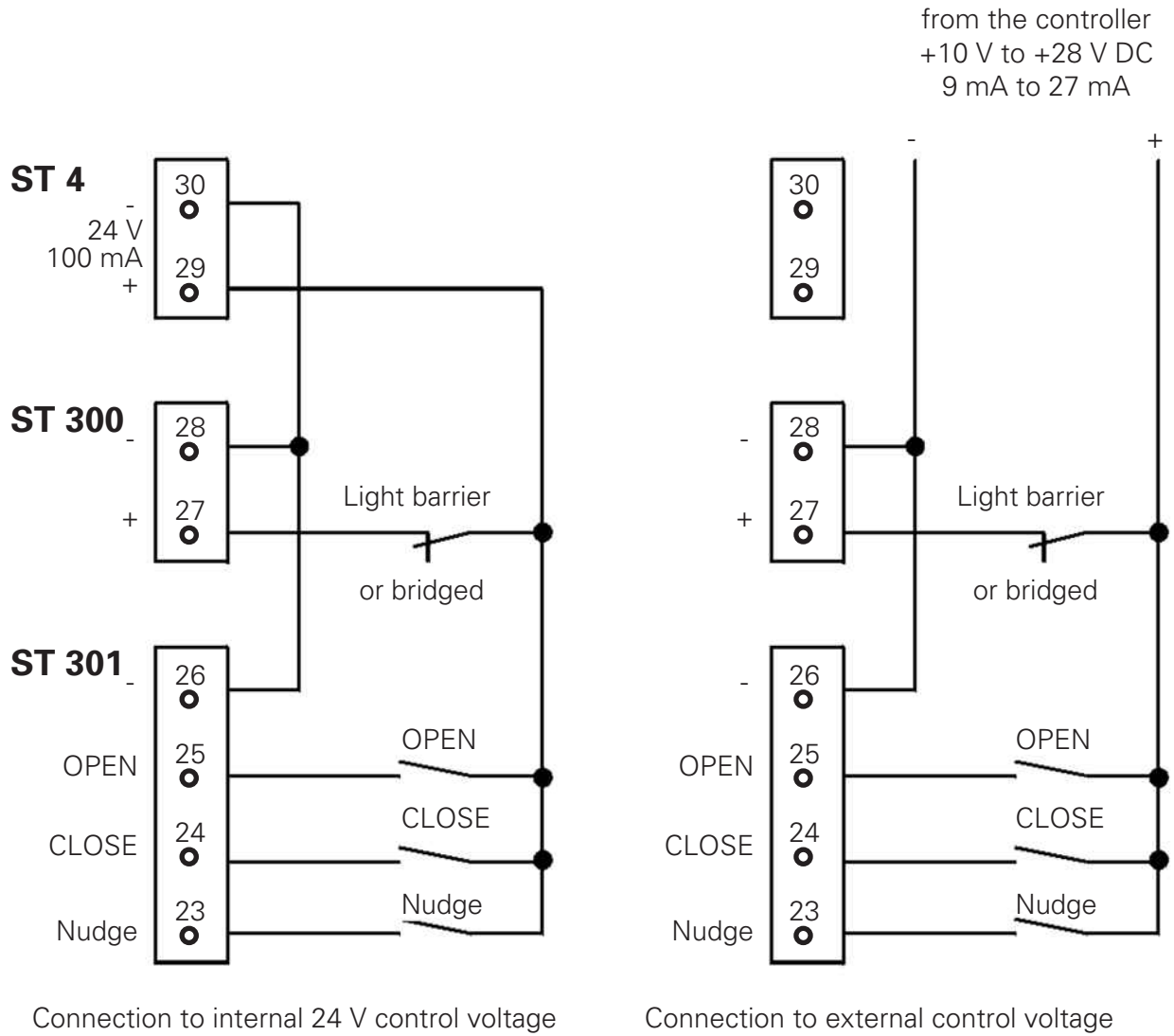

Nudge = CLOSE and Nudge commands simultaneously

13.10 Setting Log

Please keep it ready when you have questions for the hot line!

Hot line: (05 11) 8 77-14 71

Fax: (05 11) 8 77-16 30

V _{max} OPEN P-301	<input type="radio"/>				
V _{max} CLOSE P-302	<input type="radio"/>				
V _{min} P-303	<input type="radio"/>				
SLOPE P-304	<input type="radio"/>				
SWORD OPEN P-305	<input type="radio"/>				
SWORD OPEN P-306	<input type="radio"/>				
FORCE P-307	<input type="radio"/>				
SLOW OPEN P-308	<input type="radio"/>				
TERM. ON S-304	<input type="checkbox"/>				
Motor:	<table style="width: 100%; border-collapse: collapse;"> <tr> <td style="width: 50%;">40 V <input type="checkbox"/></td> <td style="width: 50%;">30 V <input type="checkbox"/></td> </tr> <tr> <td>Small motor</td> <td>Large motor</td> </tr> </table>	40 V <input type="checkbox"/>	30 V <input type="checkbox"/>	Small motor	Large motor
40 V <input type="checkbox"/>	30 V <input type="checkbox"/>				
Small motor	Large motor				
Overall door mass:	approx. _____ kg				
Door manufacturer:	_____				
7 segment display:	_____				
Lift controller: manufacturer/type	_____ / _____				
Lift Location/No.	_____ / _____				

* Lay off potentiometer position e. g.: ↻

Published by
Siemens Electronic Design and
Manufacturing Services
GmbH & Co. KG
Am Brabrinke 14
30519 Hannover

Hotline: +49 511 8 77-12 71 und +49 511 8 77-12 57
Fax: +49 511 8 77-16 30