

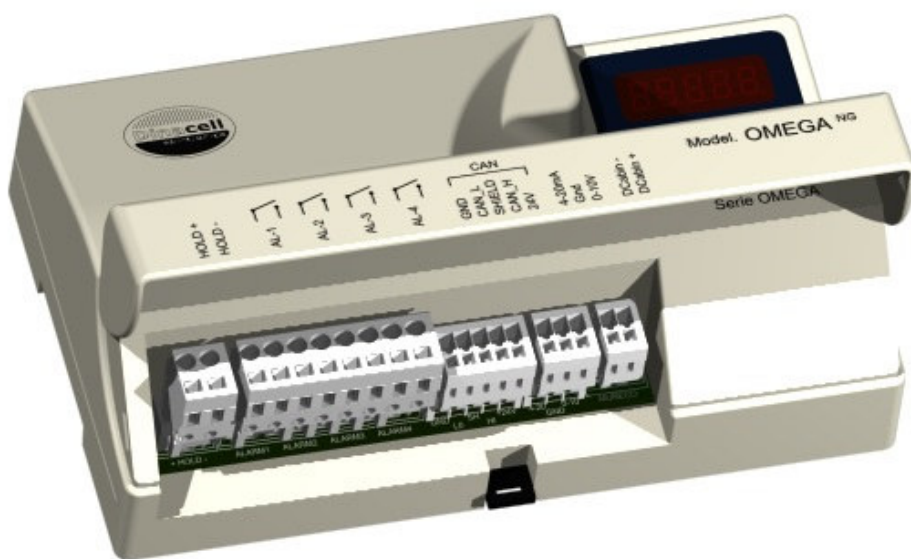

OMEGA ng

LOAD WEIGHING DEVICE

User manual



Index

1. DESCRIPTION AND MAIN FEATURES	4
2. DISPLAY AND CONTROL BUTTONS.....	4
3. DIMENSIONS, INSTALLATION AND CONNECTIONS	5
4. MENU STRUCTURE	6
5. HOW TO VISUALIZE OR CHANGE PARAMETERS	7
6. DEVICE INFO.....	7
7. SYSTEM CONFIGURATION	8
8. ALARMS CONFIGURATION	10
9. CHAIN COMPENSATION.....	12
9.1. New advanced Chain Compensation	12
9.2. Submenu Chain.....	12
9.3. Chain Compensation Adjust	13
9.3.1. Software Compensation.....	13
9.3.2. Hardware Compensation	14
10. AUTO-ZEROING COMPENSATION.....	14
11. ADDITIONAL FUNCTIONS	15
11.1. Hold function.....	15
11.2. Cabin Display (Optional).....	15
12. ANALOG OUTPUT	16
13. CANOPEN-LIFT CIA 417.....	17
14. ERROR CODES AND TROUBLESHOOTING	18
15. ELECTRICAL SPECIFICATIONS.....	18
16. NG CONECTION.....	19
16.1 Wifi NG Connection	19
16.2 Firmware Update	19
17. WIRE ROPE TENSION ADJUSTMENT.....	20
17.1 Wire Rope Tension checking Tool.....	20
17.2 Assistance to the wire rope tension adjustment.....	21
18. QUICK CONFIGURATION GUIDE	23

1. DESCRIPTION AND MAIN FEATURES

OMEGA^{NG} Unit control is a Load Weighing device of the (NG) New Generation units from Dinacell Electronic with CanOpen-Lift CIA 417 Integrated.

The Main features of this unit, depending on the model, are:

- **Measures, monitors and Indicates Overloads in elevators.**
- **Up to 12 Individual Rope Tension monitoring.**
- **Wire Rope Tension adjustment.**
- **5 Digits display with 4 LEDs for alarm indication and 2 LEDs for Can Status**
- **Hold Input (inhibit Alarms activations while lift is travelling).**
- **5 Alarms Thresholds (Full Load, Over Load, Zero Cabin, Slack Rope, Different rope Tension)**
- **4 Relays output**
- **0-10v Analog Output**
- **4-20ma or 0-20ma Analog Output**
- **Inverted Analog Output Selection**
- **Cabin Display Output**
- **CanOpen-Lift CiA 417 (Optional).**
- **Software Chain compensation.**
- **Hardware Chain compensation. (Requires additional Load Cell).**
- **Auto Zero Correction Function.**

And the new features of Our NG devices

- **Remote WIFI Programming (NG) (Requires additional device).**
- **USB connection for firmware upgrading.**

2. DISPLAY AND CONTROL BUTTONS

Functions of control buttons:

The unit is equipped with a menu by which the individual setting parameters can be displayed or modified.

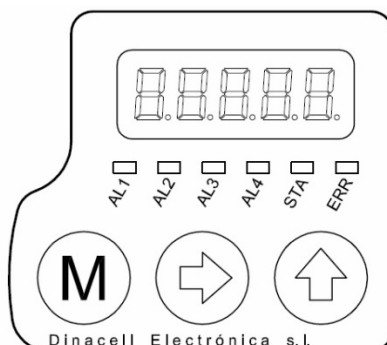

- a. By Pressing this key for 2 Seconds Enter/exit the menu
- b. By Pressing this key inside the menus will navigate through parameters.
- c. Accept and save modified values when modifications are on progress.



- a. During menu navigation: Enter to modify a parameter.
- b. While modifying a parameter: Chose digit to change.



- a. During menu navigation: Show the stored value of the selected parameter.
- b. While modifying a parameter: Change the blinking digit incrementally from 0 to 9.

Note: After two minutes without any operation, the unit automatically returns to the total weight measure display, independent of the menu item previously selected.

Led	Functions
AL1	Full Load Alarm Indicator
AL2	Over Load Alarm Indicator
AL3	Zero Load Level Indicator (Empty Cabin)
AL4	Difference and Slack Rope tension indicator
STA	Led status (For CanOpen: Status Led)
ERR	Error (For CanOpen: Error Led)

3. DIMENSIONS, INSTALLATION AND CONNECTIONS

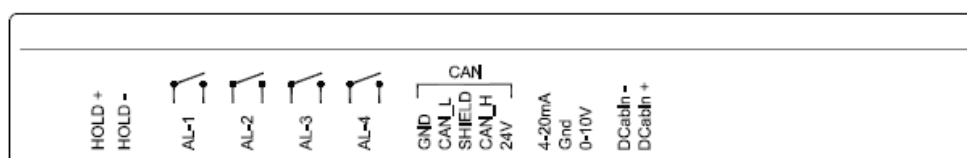
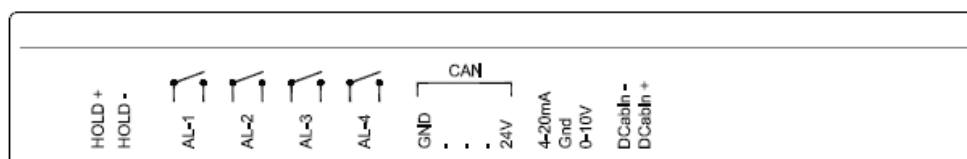
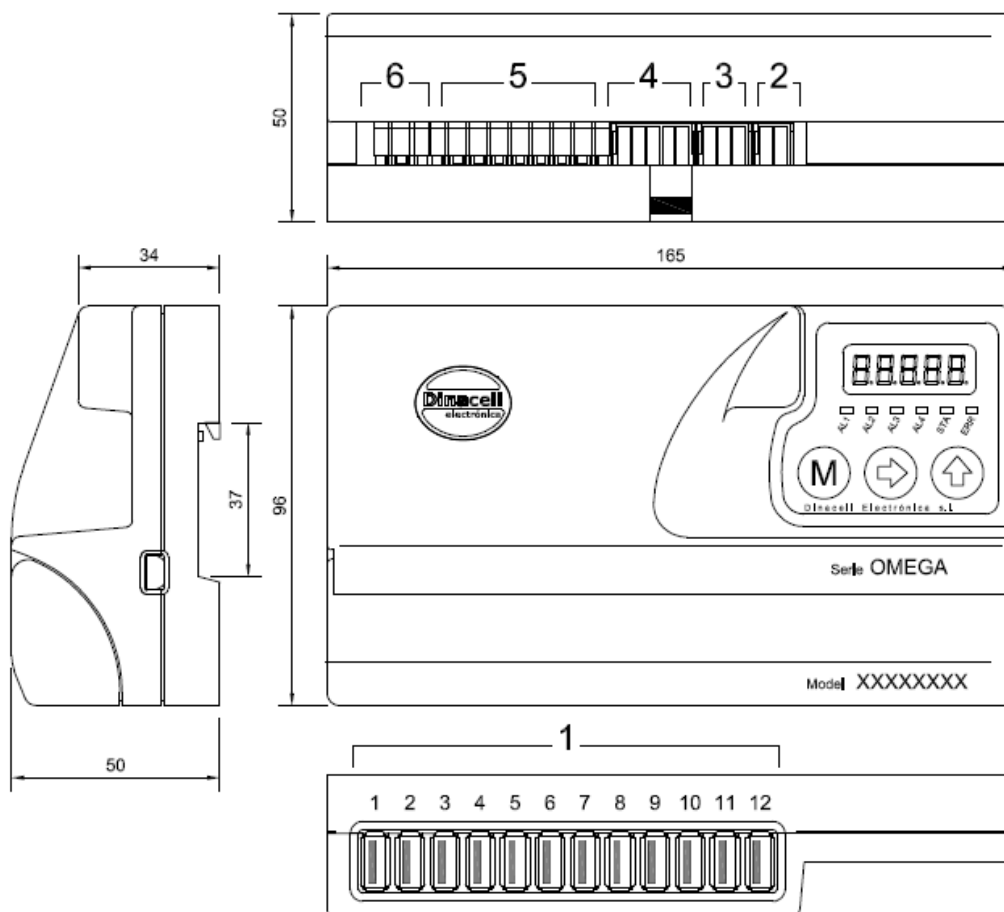

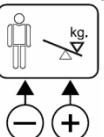
1	Sensor inputs	Up to 12 USB Connectors for easy plugging
2	Cabin display output	<p>Output there are two types of output: INC: Progressive display MB-D (two wire connection without polarity). LED: If overload, it will be an intermittent voltage of 5V (max. 30mA) with the polarity shown in the figure.</p> 
3	Analog outputs	These outputs reflect the sensors signal over the range 0-10V for Voltage and 4-20mA or 0-20mA for current. Common signal is GND. (See the ADDITIONAL FUNCTIONS chapter 12).
4	Can Open	Input 24 VDC power supply and Can Bus in an Open Style connector
5	Relay connections for alarms	Terminals for the alarm relays. (See the alarms section in chapter 8)
6	HOLD input	This function will be activated if an input voltage from 24 to 125V (DC or AC) is applied. (See the ADDITIONAL FUNCTIONS chapter 11).

4. MENU STRUCTURE

The menu has the cyclic structure shown in the following figure.



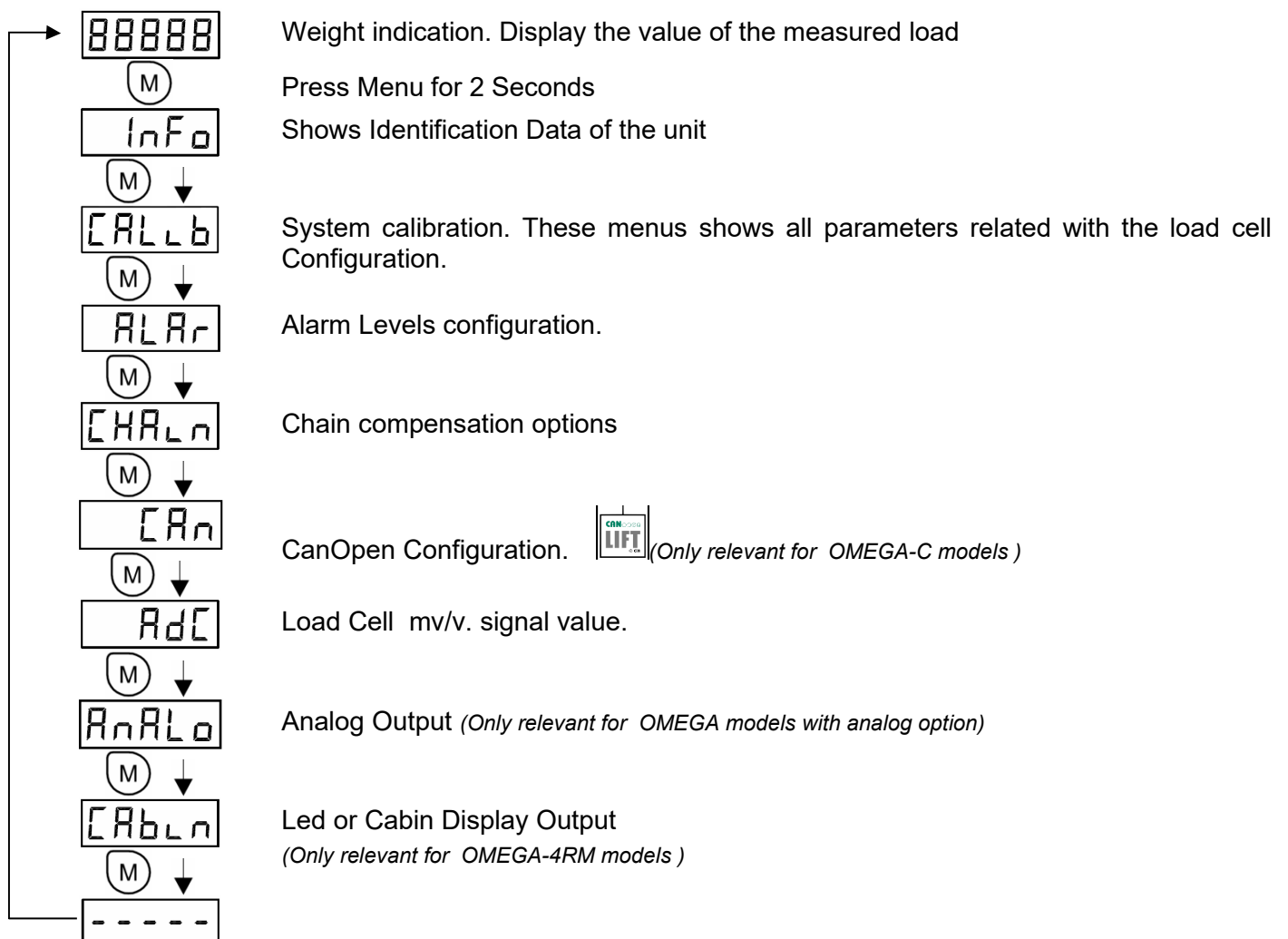



Press  button for 2 seconds to enter and then press it repeatedly to move from a parameter to another. Press it for 2 seconds to exit.





Pressing Menu for 2 seconds inside the internal navigation menu will end the menu navigation and return to Display the value of the measured load

5. HOW TO VISUALIZE OR CHANGE PARAMETERS

Once inside any menu and displaying the parameter to be viewed or changed:

- Press  to display the current value.
- Press  to select the parameter to be modify :
- Press  to choose the digit position to change (Flashing)
- Press  to change the value of the Current Flashing digit position. (if there's no flashing digit, change the value with  key directly)
- Press  twice to save the value.

 If  button is not pressed twice before display Flashing ends (10 seconds), the parameter value will not be changed.

After any of these operations, the display will show the current parameter.

6. DEVICE INFO

All new NG units store some important information in this menu in order to build wireless connections with any remote future unit developed by Dinacell Electronica. All parameters can be read in this submenu.

Submenu InFo

Press to enter

Check value



Enter to modify

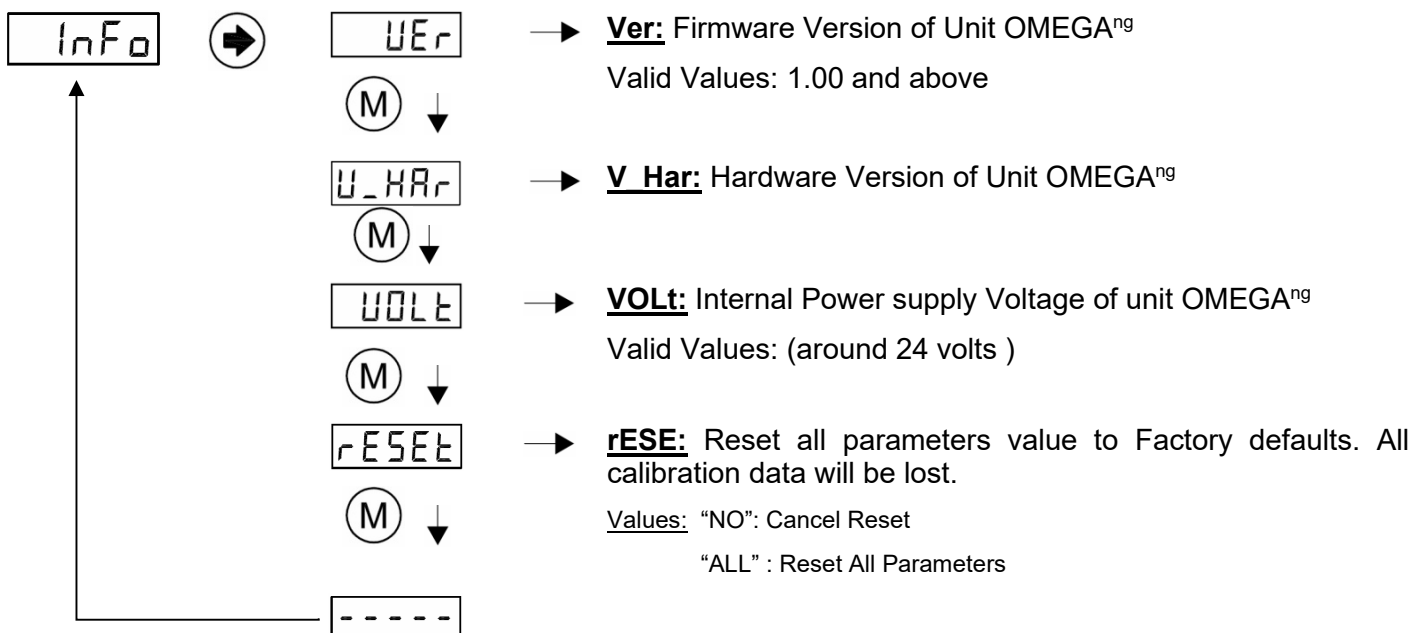

7. SYSTEM CONFIGURATION

This section describes how to configure the Unit to obtain the best measure accuracy. The configuration is done in **CALCb** Menu.

	Press to enter		Check value	↑	→	Enter to modify
	→	nSen	→	nSen: Number of sensors connected to ropes or cables. If this parameter is not set correctly, the unit will show Err1 and alarm relays will be activated.		
		(M) ↓				
	→	Iref	→	Iref: Initial Reference for the individual Rope Tension sensors (SWR, SWK, Hitch Point Sensors). This operation must be done with the Sensors not installed on the ropes. <i>Note 1:</i> It is mandatory to do the Iref operation for Rope Tension Equalizing <i>Note 2:</i> Iref is not needed For sensors under cabin (TCA) or Beam sensors (SV). If rope tension equalization is not required or you forget to make this operation, just set this option to "None" in Iref Submenu to make the operation with sensors already installed.		
		(M) ↓				
	→	Units	→	Units: Display Weight units. Available units are Kilos/Pounds		
		(M) ↓				
	→	SusPE	→	SusPE: Type of suspension at installation: 1:1 2:1 3:1 4:1 <i>Note :</i> Suspension should set to 1:1 For sensors under cabin (TCA) or Beam sensors (SV)		
		(M) ↓				
	→	Zero	→	Zero: Zero point adjustment With empty elevator. Store a Countdown value for Zero and load calibrating parameters		
		(M) ↓				
→	LoAd	→	Load: A well known weight must be placed inside the elevator to do the load setting of the unit. (It is recommended to set up a minimum of 60% of the nominal load of the elevator being adjusted).			
	(M) ↓					
→	CELL	→	Cell: Nominal load cell sensibility. This value is calculated when LOAD operation is done. User should not modify this value. (If this parameter is modified the previous calibration settings will be overwritten)			
	(M) ↓					
→	tSen	→	tSen: Raw Rope Tension of each individual Sensor. On the display appears the weight in units selected (e.g. 100kg) alternating with the Sensor number (SE 1, SE 2, etc.)			
	(M) ↓					

Calibration process:

- 1) Install the control unit with the information of the *INSTALL AND CONNECTIONS* Chapter 3.
- 2) Connect Load Cell to the OMEGA^{ng}
- 3) Power up the unit with the correct voltage (see the *ELECTRICAL SPECIFICATIONS* Chapter 15).
- 4) Go to **CALLb** Submenu:
- 5) Detail Calibration Procedure:

Follow next steps to set a precise Load Measuring system

nSEN

5.1) Select number of ropes.

IREF

5.2) Do an Iref “**ALL**” Operation with rope sensors **NOT INSTALLED** on the ropes. and a 5” seconds countdown occurs.

Note: for hitch point sensors, or if your sensors are already installed, or if you don’t need to equalize the individual rope tension, just select “**None**” option in Iref submenu for this operation.

Iref is not required for TCA or SV Sensors.

UNLTS



5.3) Select display measuring units. Available units are Kilograms or Pounds

SUSPE

5.4) Select Suspension. By default 1:1 is selected. (Select 1:1 for TCA and SV Sensors)

ZERO



5.5) **Zero adjustment:**

- a) Install sensors on ropes when using SWK, SWR or LCA.
- b) Select Submenu **Zero** by pressing 
- c) Change countdown value if desire.
- d) Press menu  and display will start flashing
- e) Make sure elevator is empty and confirm operation by pressing  again.
- f) The countdown will start. During this time, the car weight must not change.

LOAD

5.6) **Load Point adjustment:** This function ensures the accuracy of the control. Put a well known weight into the cabin. It is recommended to place into the cab a minimum weight of 60% of the elevator duty load. (**100% is preferred.**)

To make the Load point adjustment:

- a) Select Submenu Load by pressing 
- b) Set the value with the total Load added into the elevator.
- c) Press menu  and display will start flashing
- d) Confirm operation by pressing  again.
- e) The countdown will start. During this period of time, the car weight must not change

CELL

5.5) This parameter stores the Sensor Sensibility. Cell value is automatically calculated after a Load Point adjustment. This parameter can be Set when using Calibrated Sensors with known Cell value. If Cell Value is changed, the previous calibrating process will be

overwritten.

8. ALARMS CONFIGURATION

The alarms values correspond to the load threshold at which each relay change its state.

The relays allows to be configured individually as make or break contact

Alarms are activated when their threshold is exceeded. The Unit OMEGA^{ng} has 5 different alarms:

AL1-F (Full Load, Relay #1):

Change of state when exceeding the load programmed in

AL2-O (Over Load, Relay #2):

Change of state when exceeding the load programmed in

AL3-E (Empty Load, Relay #3):

Change of state when falling below the load programmed in

Note: *This alarm is active below Alarm3 Threshold.*

AL4-d (Rope Tension Difference, Relay #4):

Change of state if **any rope deviates from the average of all other ropes** at least by the **percentage** programmed in .

AL5-S (Slack Rope, Relay #4):

Change of state if any rope has a slack rope tension (A value below alarm level threshold)

When Slack Rope Alarm is activated the word "Slack" will flash on the display.

The working procedure of the relays as a make or break contact can be changed for each alarm output

using the parameter. **Valid values are (Close) for the operating mode MAKE and (Open) for the operating mode BREAK. Close is a normally closed relay and OPEn is a normally open relay.** Alarm LEDs indicators will be activated when the display measured value overload corresponding alarm level



Note: LEDs are not related to relay state but alarms levels.



Note: AL4-d and AL5-S share the same relay Output. When there is a slack rope, the Display will show the word "Slack" on it.

How to configure alarm settings:

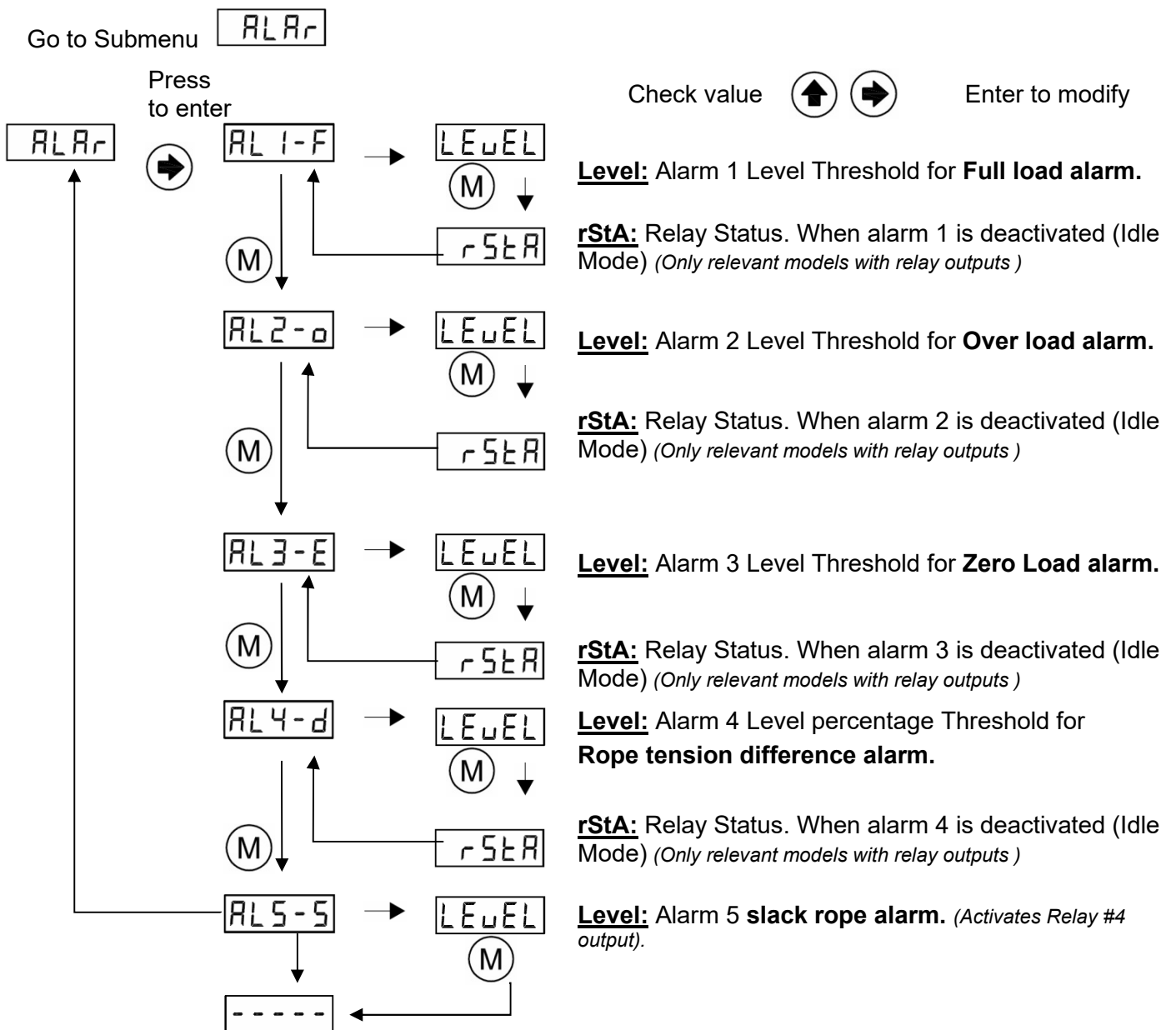

All Displayed weights and alarm thresholds are shown in selected units. All internal calculations are made in kg, therefore, rounding errors are possible

9. CHAIN COMPENSATION

9.1. New advanced Chain Compensation

The New Generation (NG) of Load Weighing Devices has the newest software for chain compensation. It offers several options to improve the accuracy to compensate for the weight of the chain. In this Submenu, the user can choose between three options, no compensation, software compensation and hardware compensation.

 **Hold Input must be wired to use the Software Chain compensation Function.** (See Hold Function Section 11.1)

9.2. Submenu Chain

Submenu [CHALn]

Press to enter

Check value



Enter to modify

<div style="border: 1px solid black; padding: 2px; display: inline-block;">[CHALn]</div> <div style="display: inline-block; vertical-align: middle; margin-left: 5px;"> </div>	<div style="border: 1px solid black; padding: 2px; display: inline-block;">TYPE</div> <div style="display: inline-block; vertical-align: middle; margin-left: 5px;"> ↓ </div>	→	Type: Type of chain compensation applied. User can choose between hardware compensation, software compensation or none compensation
	<div style="border: 1px solid black; padding: 2px; display: inline-block;">VALUE</div> <div style="display: inline-block; vertical-align: middle; margin-left: 5px;"> ↓ </div>	→	Value: Max Chain value to compensate. At installation. Valid Values : 0-600 (Set Value to 0 to deactivate software compensation).
	<div style="border: 1px solid black; padding: 2px; display: inline-block;">[bot</div> <div style="display: inline-block; vertical-align: middle; margin-left: 5px;"> ↓ </div>	→	C Bot: Chain zero operation at the ground floor (only applies to Hardware compensation).
	<div style="border: 1px solid black; padding: 2px; display: inline-block;">[top</div> <div style="display: inline-block; vertical-align: middle; margin-left: 5px;"> ↓ </div>	→	C Top: Chain load operation at the top floor (only applies to Hardware compensation).
	<div style="border: 1px solid black; padding: 2px; display: inline-block;">[HAR</div> <div style="display: inline-block; vertical-align: middle; margin-left: 5px;"> ↓ </div>	→	C Har: Real chain load value compensated by hardware measure in selected units (only applies to Hardware compensation).
	<div style="border: 1px solid black; padding: 2px; display: inline-block;">[HCEL</div> <div style="display: inline-block; vertical-align: middle; margin-left: 5px;"> ↓ </div>	→	ChCEL: Nominal Chain load cell sensibility. This value is calculated when C_Bot or C_top operation is done. User shouldn't modify this value. (If this parameter is modified the previous calibration settings will be overwritten)(only applies to Hardware compensation).
	<div style="border: 1px solid black; padding: 2px; display: inline-block;">[SOF</div> <div style="display: inline-block; vertical-align: middle; margin-left: 5px;"> ↓ </div>	→	C Sof: Chain load value compensated by software estimation in selected units
	<div style="border: 1px solid black; padding: 2px; display: inline-block;">t1</div> <div style="display: inline-block; vertical-align: middle; margin-left: 5px;"> ↓ </div>	→	Time 1: Starting Time to hold the weight before Hold input is activated. It is an optional correction on installations where the Hold Input is activated too fast. (Units are tenths of seconds). (Default Recommended Value: 2 (0.2secs)). (only applies when hold input is connected).
	<div style="border: 1px solid black; padding: 2px; display: inline-block;">t2</div> <div style="display: inline-block; vertical-align: middle; margin-left: 5px;"> ↓ </div>	→	Time 2: Delay time to release hold weight after Hold input is deactivated. It is an optional correction on installations where the Hold Input is deactivated too fast. (Units are tenths of seconds). (Default Recommended Value: 4 (0.4secs)). (only applies when hold input is connected)
	<div style="border: 1px solid black; padding: 2px; display: inline-block;">-----</div>		



T1 and **T2** options are only **shown** if `TYPE` is set to **SOFT** compensation. See Section 10 , Hold Function to adjust these parameters.

9.3. Chain Compensation Adjust

The NG Series has new advanced chain compensation. To use all the features of new compensation is necessary to adjust some parameters in `CHAIN` Menu.

There are two types of compensation.

- **Software chain compensation:** When selected, the unit compensates the chain with hold signal activations/ deactivations.

Note: `TYPE` and `VALUE` parameters must be set to use the Software Chain compensation.

- **Hardware chain compensation:** When selected, the unit compensates the chain with the on real time weight of the chain. This can be done using the auxiliary Load Cell input for chain compensation and adjusting the `CHAIN` parameters for hardware compensation.

Note: To deactivate all chain compensations just set Type parameter to **none**.

`TYPE` Set Type to `None` value.

9.3.1. Software Compensation

This function compensates the weighting difference between floors produced by the extra weight of the chain and the travelling cables. The unit needs the HOLD signal to be active when the doors closed to compensate the weight during the elevator movement.

To configure the software compensation:

`TYPE` Set Type to **SOFT** value.

`VALUE` Set the estimated weight of the chain. This parameter will be the maximum value compensated by software compensation

`SOFT` In this parameter you can check the value the OMEGA^{ng} is compensating by software each time the HOLD signal is deactivated

When using software compensation, Auto_Zero compensation will be activated automatically.

9.3.2. Hardware Compensation

In some installations with many landings, software chain compensations does not work well due to friction in the rails between floors, weight changes during long elevator travels, or auto_zero does not occur because elevator never stops.

These problems can be solved with Hardware compensation.

It is mandatory to plug an auxiliary Sensor when hardware compensation is selected.

A dedicated Load Cell for chain compensation is needed. Otherwise Err11 will flash in the display.

A system Configuration (Section 7) must be done previous to set the Hardware compensation parameters.

[TYPE] Set Type to Hard value

[C bot] Take the elevator to the ground floor and set C_Bot To Yes. A Countdown will start.

[C top] Take the elevator to the Top floor and set C_TOP To Yes. A Countdown will start

[HAR] In this parameter you can check the value the OMEGA^{ng} is compensating by hardware with the chain load cell

10. Auto-Zeroing Compensation

The Auto_Zero compensation is designed to automatically remove small measurement errors

lower than parameter **[CHARn]** → **[TYPE]** → **[VALUE]** →

The Auto-Zero function will happen whenever the OMEGA^{ng} detects a total unload of the elevator and measures a static offset of ± **[VALUE]** for a period of at least 60 seconds. During this time the measured load must not change by more than ±20kg.

To eliminate the Auto_Zero compensation, a Zero operation should be done.



If **[CHARn]** → **[VALUE]** is set to "00000" Auto_Zero compensation will be automatically **disabled**.

11. ADDITIONAL FUNCTIONS

11.1. Hold function

During the elevator travel, the measured loads can greatly fluctuate due to friction in the rails, cab and load movements, etc. The Hold Input prevents the control from measuring the load while the elevator is travelling, This ensures that the movement of the cabin will not affect the weighing process and therefore, no alarms or relay will be activated during elevator travel.

How Hold Input Function works:

- When a voltage in the range 24-125V (DC or AC) is applied in this input, the unit holds the last stable measurement of weight acquired.
- The voltage must be applied when the doors close and it must be removed as the doors open.

This ensures that the movement of the cabin will not affect the weighing process and therefore, no alarms or relay will be activated during elevator travel.

The OMEGA^{ng} unit has an internal register that stores all previous weighting measures of the last 3 seconds. As some installations sets the HOLD input at the same time the doors closes, it may happen that the last measure obtained could not be as stable as desired. The same issue might happen when removing the HOLD input as the doors Open

To improve the hold of a stable measure two parameters have been added at CHAIN menu

and .

As some installations sets the HOLD input at the same time it closes the doors, sometimes the last measure obtained is not as stable as desire. The same issue can happen when removing the HOLD input and the doors Open.

- Time in tenth of seconds to take the measure before the HOLD signal is active.
- Time in tenth of seconds to update the measure after the HOLD signal is released.

Note: For example; With T₁ set at 10 and T₂ set at 15:

When the hold signal is activated, then the OMEGA^{ng} will take as a valid load measurement the value that was stored 1 second before HOLD signal was activated. Then when HOLD input is released, the first stable load value will be taken 1.5 seconds after the hold signal is deactivated.

This option offers great flexibility to resolve problems in some critical installations.

11.2. Cabin Display *(Optional)*

It provides two types of output depending on the Cabin Display (CDISP) parameter:

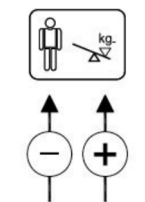

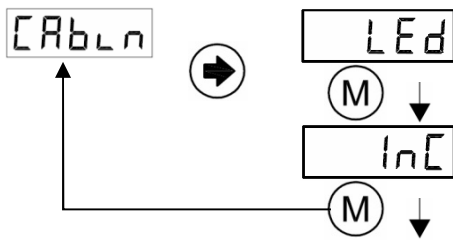

→ **LED Indicator:** Under overload it will be an intermittent voltage of 5V (max. 75mA) with the polarity shown in the figure.

→ **LED Incremental** Progressive display MB-D is used (two wire connection with polarity) *(Requires an external MB-D unit)*.

12. ANALOG OUTPUT

The unit is provided with two analog outputs (Voltage and current output). Both Outputs are active and operative at same time.

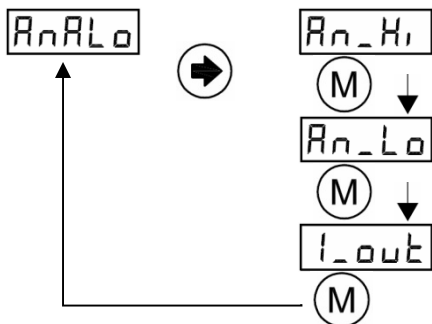

→ **Analog High:** Set the Load value desired (kg or Lb) To deliver the maximum analog output (10v or 20 ma)

→ **Analog Low:** Set the Load value desired (kg or Lb) to deliver the minimum analog output (0v, 0ma or 4 ma)

→ **Type of current output:** Set the desired current output range. It can be configured as 4-20 or 0-20 ma.

This function reflects the Display measure over the range between analog Low and analog High values.

Voltage Output	An_Low Value	An_High Value	Range	Voltage Output Value
0-10 volts (0-5 Optional)	0Kg	100Kg	When weight ≤ 0kg (empty elevator)	0 V
			When weight ≥ 100kg	10 V (5VOptional)
	100Kg	0Kg	When weight ≤ 0kg (empty elevator)	10 V (5VOptional)
			When weight ≥ 100kg	0 V
Current Output	An_Low	An_High	Range	Current Output value
0-20 ma 4-20ma	0Kg	100Kg	When weight ≤ 0kg (empty elevator)	0 or 4 ma
			When weight ≥ 100kg	20 ma
	100Kg	0Kg	When weight ≤ 0kg (empty elevator)	20 ma
			When weight ≥ 100kg	0 or 4 ma



When hold (inhibit) input is activated the analog output will not change during elevator travel, until hold input deactivation.

13. CanOpen-Lift CiA 417



(Only relevant for OMEGA-C and OMEGA- CA models)

Dinacell electronic is member of the CiA (Can In Automation),
Vendor-ID 00000361



OMEGA^{ng} -C accomplish with the CanOpen-Lift CiA 417 profile.

Some important CanOpen Parameters can be modified from this Submenu as, Baud rate and Node ID. Weigh change detection is a threshold that will send a PDO message when the weight change overpasses the value.

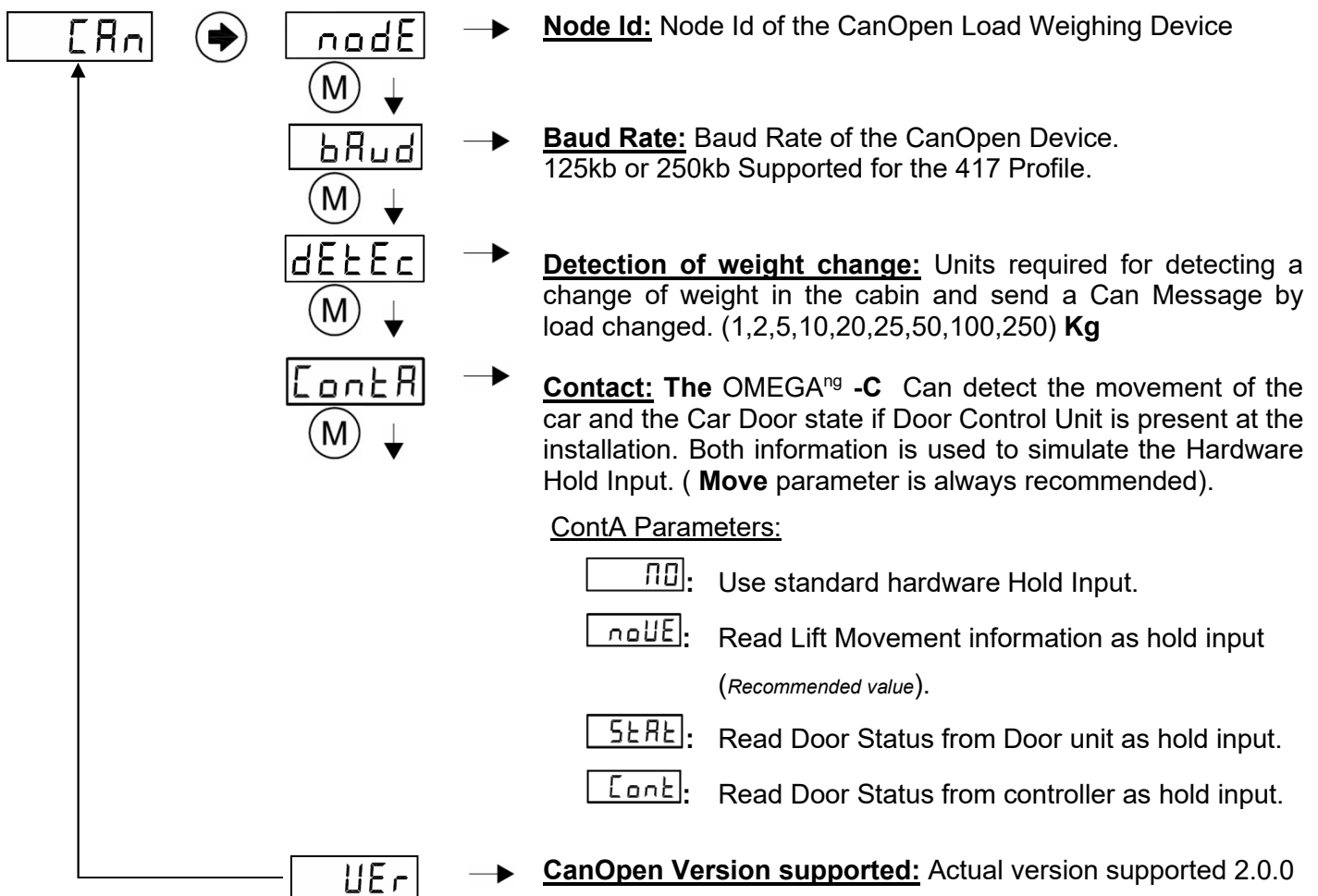

Bus Connection must be according application profile CiA-417 CAN high speed standard (ISO99-2) .



If the Load Weighing unit is set at the end of the installation end, a 120 Ohm resistor must be placed on the connector between Can High and Can Low lines.

14. ERROR CODES AND TROUBLESHOOTING

When the unit detects some anomaly it will show an error code from the following table:

	Error description	Action
Err1	Load cell is not properly connected, or its cable is damaged. Err1 is shown alternating with the number of faulty Sensors(Se-1,Se-2,etc..)	Check the indicated sensor connection.
Err2	Negative overflow. The load cell is giving a too high negative signal.	Check the load cell connection. It should be no negative charge. (Recalibrate per Section 7).
Err3	Positive overflow. Load cell is holding a higher load than its nominal value.	Change the load cell by another with higher nominal load. (Recalibrate per Section 7).
Err6	Loss of data in memory. Notice: When this error appears, relays will change to OPEN state.	The unit must be reset to its default values
Err7	Load cell with very low sensibility. The unit was not properly adjusted or load cell has a low nominal value.	Adjust the zero and Load again. Change the load cell by another with lower nominal load.
Err11	Chain Load cell is not properly connected, or its cable is damaged, or wrong number of sensors set in parameter nSens .	Check the chain load cell connection. If no Hardware chain compensation desired, change Type parameter at menu chain to None or soft



Important: When an error appears, all alarms are activated and the elevator remains blocked.

RESTORING THE FACTORY SETTINGS (Only in case of configuration problems)

Just go to menu **Inf0** and set **rESEt** option to **yes**:

15. ELECTRICAL SPECIFICATIONS

Power supply characteristics	Short-circuitable. It is not necessary to replace any fuse.
Nominal voltage	12-40 VDC
Maximum current	<200mA
Relays Contacts (Nominal Switching Capacity)	4 Relays: 250VAC / 3A - N.O.
HOLD Input	24V-125V AC/DC
Box	IP-50 V0 fireproof plastic.

16. NG CONECTION



All New Dinacell Units have a special feature called NG Connection (New Generation connections)

The main function of the NG connection is to connect to android Smart phones for Unit calibration, and reading Pen Drives for software updating.

To use all advanced features of NG Connection, user needs to connect the WRCT^{NG} adapter.

16.1 Wifi NG Connection

Connect the WRCT^{NG} adapter to the unit OMEGA^{ng}. **Dinacell TOOLS Application software** must be installed in a smart Phone or Laptop.

Users can download the Dinacell Application “**Weighing NG**” from Google Play Store market or from Apple Store.

With the New WRCT^{NG} adapter connected to the NG Connection located on the side of the OMEGA^{ng} Control, users can:

- Get all parameter values of the unit in real time.
- Calibrated the unit without using the key board.
- Test the installation performance.
- Check and review measurements to adjust rope tensions, guides, detect friction problems during travels, etcetera.
- Save all Calibrating parameters data in a Pdf report.
- Send reports by email.
- Stores all installation calibrations in a single phone.
- And more, as the software is in continuous development.



16.2 Firmware Update

It is possible to update the firmware of any NG Device using the NG connection located on the side of the OMEGA^{ng} Control and a Flash Pen drive. You need a standard Mini USB-B to USB-A plug adapter to connect the Flash drive to the Unit.

Follow next steps to enter in Boot loader mode for firmware updating:

- Copy new firmware (.CYP file) in the Flash Pen drive.
- Plug the Pen drive in the auxiliary USB cable adapter from USB to Mini USB.
- Switch off the unit OMEGA^{ng} by removing the power supply.
- Press key and **apply power to the unit with the key pressed**. ERR LED will flash each second, and 5 Digits display will be switched off.
- Plug the Mini USB cable on the NG connector. STA LED Will be ON and ERR LED will Flash Faster (each 0.5 second)
- Be patient and Wait until unit reboots. The process can take up to a minute.

- g) When programming ends the Unit Will reboot automatically. Then Go to Info Sub-menu and Reset the unit.

17. **WIRE ROPE TENSION ADJUSTMENT**

This section explains how to check the tension of all wire ropes of the installation. All ropes should carry the same tension. Equally tensioned ropes improve ride quality and extend life of ropes and sheaves.

Nowadays most elevator systems have multiple wire ropes attached to the cabin and counterweight. This ropes normally run over a traction sheave or pulley just to move the cabin up and down the hoistway.

When some ropes have more tension than other, the ropes with lower tension will slide over the pulley and can produce a crown groove wear at the sheave. It is possible to detect this wear by rope slapping, vibrations on the cables, or metal dust on the pulley.

Normally, the system works better if all the ropes have similar tension (about $\pm 5\%$) of the nominal load of the installation.

Although some installers manage to adjust the rope tension manually just touching the ropes or Just tuning the installation plucking each rope as a harp string, the best way to do this operation is measuring the load on all the ropes and displaying it in real time.

Usually Load weighing devices manufactures have dedicated and expensive tools to do this operations.

But the OMEGA^{ng}, can be used not only as a good Load Weighing device but as an additional low cost rope tension balancing tool also.

And as the unit will be installed for life you will have a permanent tool to adjust wire rope tension and detect slack ropes at the installation in real time.

17.1 **Wire Rope Tension checking Tool**

The only tool needed to adjust the wire rope tension is the **WRCT^{NG} dongle** and a Smartphone a tablet or a laptop. Then from the rope tension screen you will visualize the load of each rope in real time Now it is possible to adjust the tension of each rope to make then equal.

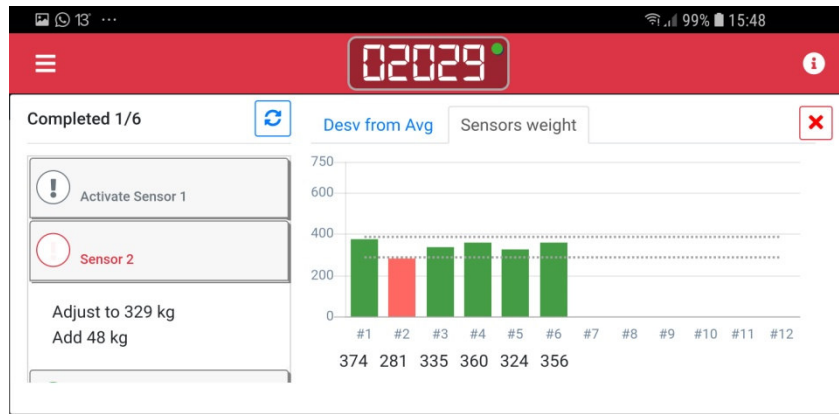

17.2 Assistance to the wire rope tension adjustment

With this assistant tool you will be guide to adjust each rope with the adequate load just to

accomplish the desired target. To enter this mode just push **Start** label

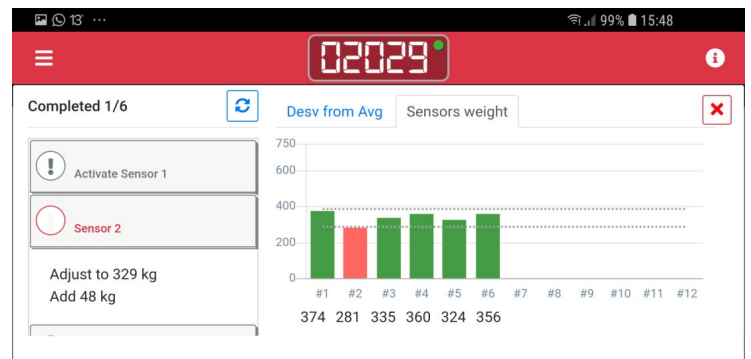
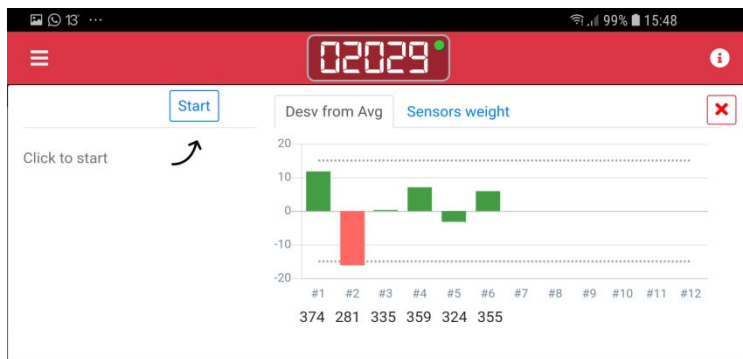

Following the suggested steps, you can apply the precise load to each rope to perform the whole "wire rope tension" process, just in a few minutes.

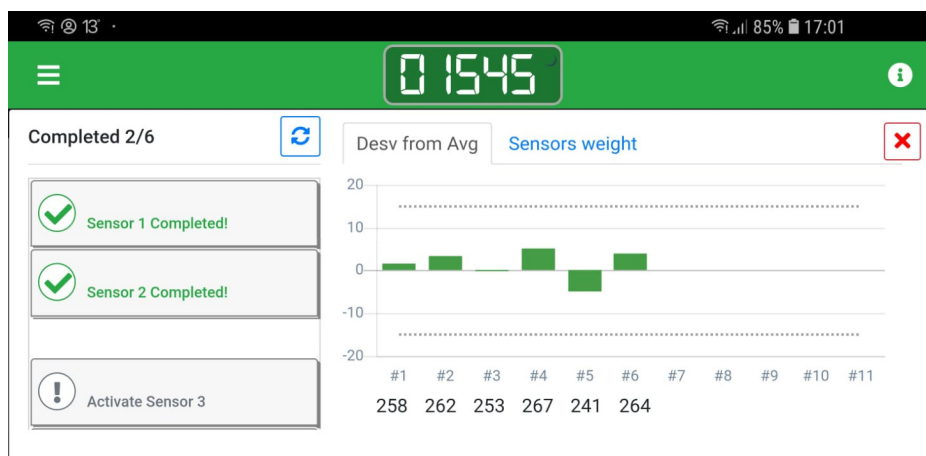

Now, you can check the final result of the adjustment process.

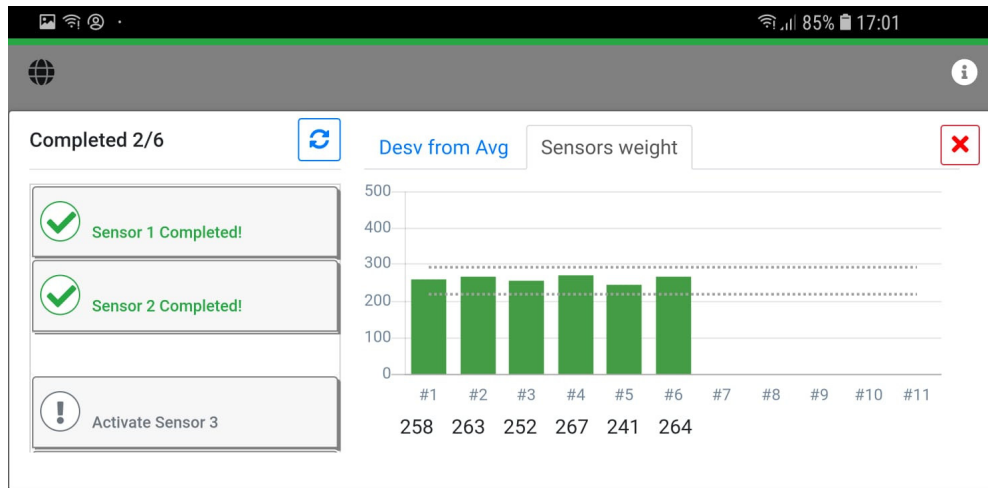

You can save all your installations data on your Smartphone, tablet or laptop. You can save as many installations as you desire (the only limitation is the memory of each device). Sending reports by mail or create your own PDF reports are also possible from the tool.

Laptop Configuration Software:

Same operations can be done from a laptop or any computer with WIFI connection.

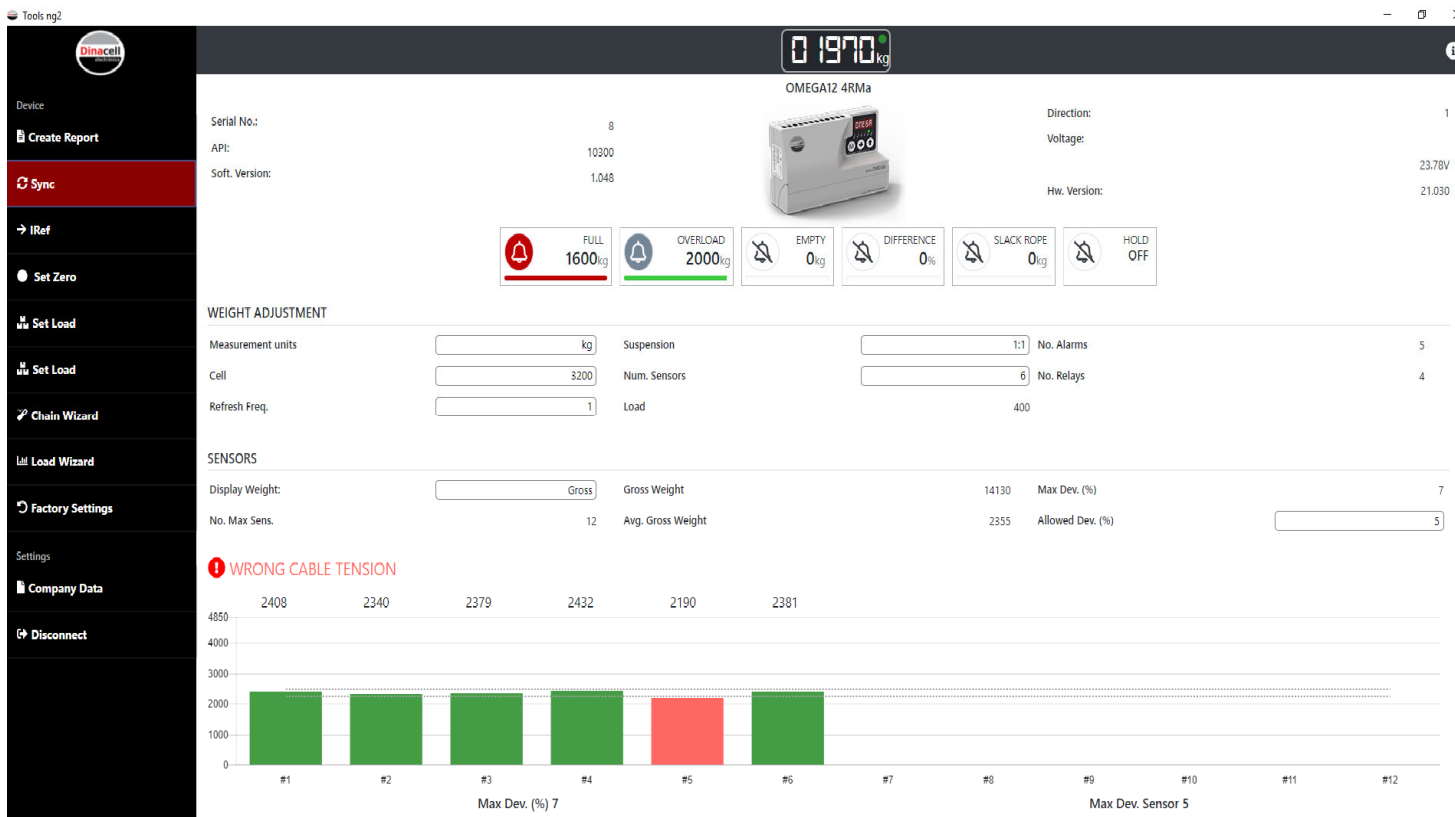

18. QUICK CONFIGURATION GUIDE

- Parameters checking or modification

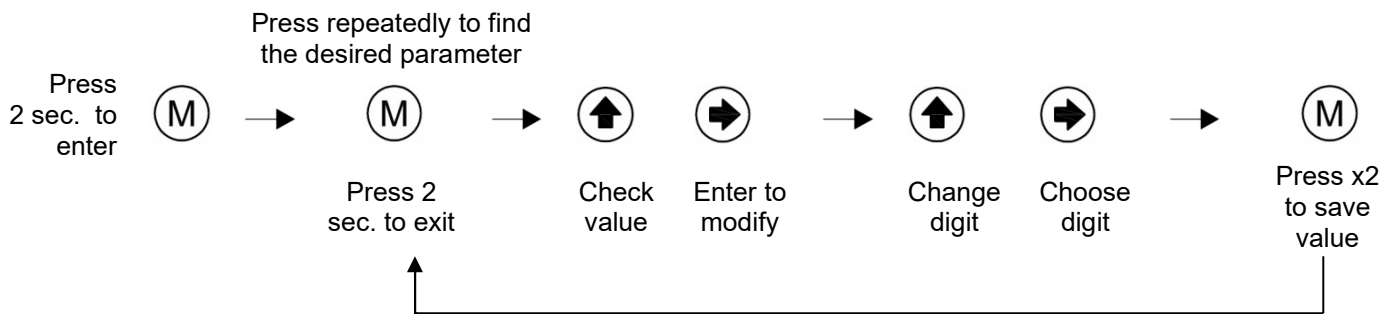

- Quick System configuration

1. Install the OMEGA^{ng} in an appropriate location.
2. Connect all sensors to the unit and relay outputs if necessary(do not install sensors on the ropes yet)
3. Go to `[ARLb]` submenu
4. Set the number of sensor (ropes) `[nSEN]` of the installation.
5. Do and `[irEF]` operation for **all** sensors when using rope sensors. (For Hitch point sensors and others select **None**);
6. Set `[UnLTS]` to kilo or Pounds
7. Set the Suspension Factor `[SUSPE]`.
8. **Install the sensor on the Ropes** when using rope sensors.
9. Empty the elevator and set the countdown value for calibrating operations. Confirm the value `[ZER0]`.for Zero Operation. A countdown will start.
10. Set a well-known weight inside the cabin and adjust `[LOAD]` parameter with the weight added. A countdown will start.
11. Set the alarms thresholds `[LEUEL]` for each alarm and the activation state `[rStA]` for each relay.
12. If chain compensation is desired, select the type `[tYPE]` of compensation you want to use.
 - If **software** compensation is selected then connect the hold input to the LWD and set the estimated weight value in Menu Chain `[CHARn]` → `[VALUE]` option.
 - If **Hardware** compensation is selected then a `[Cbot]` operation must be down at the bottom floor, and afterwards a `[Ctop]` operation should be done at the top floor of the installation. (Remember to do both operations with **no weight** inside de cabin).
 - If `[tYPE]` is set to `[None]`, the chain compensation will be disabled
13. Auto Zero Function: The maximum value in `[CHARn]` → `[VALUE]` will be used for auto zero function corrections (default value is 200). If value is set to “00000”, auto zero function and the chain compensation will be disabled.

Dinacell Electrónica sl. tiene todos los derechos reservados.

Según las leyes de propiedad intelectual, queda prohibida la copia, reproducción, adaptación, alteración o modificación, total o parcial, de los contenidos, salvo para uso exclusivo y privado del usuario o bajo expresa autorización de **Dinacell Electrónica sl.**; no responsabilizándose de los posibles errores de impresión o copia.

Dinacell Electrónica sl.

Pol. Ind. Santa Ana C / Torno Nº 8 – 28522 - Rivas Vaciamadrid - Madrid

Tel.: +34 91 300 14 35 - Fax.: +34 91 300 1645 - www.dinacell.com

D1201-04
14-Feb-20